

System

**TRUMPF**

Am Steinkreuz 2  
 D 95473 Creußen  
 Phone: + 49 92 70 / 9 85 - 0  
 Fax: + 49 92 70 / 9 85 - 99  
 E-Mail: info@pass-ag.com  
 Internet: www.pass-ag.com

**price list 12/05-T**

**Machine groups: Classification**

A	B	C	D	E	F	G	H	S	I
CN 700	CN 901E	CN 1200S	TRUMATIC	SUNIMAT 400	TRUMATIC	TRUMATIC	TRUMATIC	TRUMATIC	TRUMATIC
CN 900	CN 902	CN 1200A	20	Trumatic Trumatic	150W	20aW	500R	100	2000R
CN 701	CS 75	CS 15	20a	150K 202K	152W	202W	200R	120R	2020R
CN 901	CSCS 75.2	CS 20	202M	151K 225K	180W	300W	600L	160R	3000L
		CS 20a		152K 235K	180.2W	300LW	190R		3000R
		MP 25		180K 300K	180R	300PW			5000R
		MP25D		180.2K 300LK	180.2LW	300top			6000L
				180KD 300PK	180.LW	400W			
				180LK 400K	ELX/SWIFT				
				180.2LK	185				
					240				
					240R				
					250				
					260R				

Round Tools

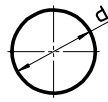

Square Tools

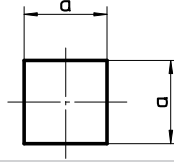

Rectangle Tools

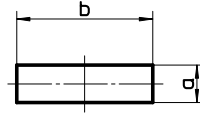

Oblong Tools

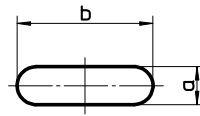

Special Shape Tools Group 1



Special Shape Tools Group 2



Special Shape Tools Group 3



Special Shape Tools Group 4

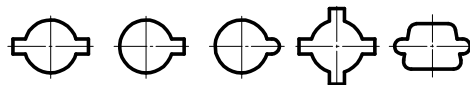

Fully guided Tools

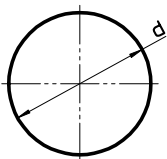
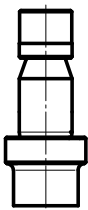
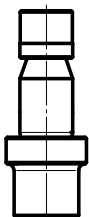
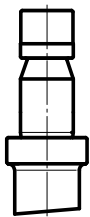

Punch							
		HSS / Flat/ 34,3 mm long		HSS / Flat/ 37,8 mm long***		HSS / Whisper/ 37,3 mm long	
							
Size	dim. "d" in mm	part.-no.	price	part.-no.	price	part.-no.	price
<b>0/A</b>	1,00-6,00	107A01	*	107A11			
<b>0/B</b> <small>(shaft 10,5)</small>	1,00-6,00	107C01	*	107C11			
<b>0/B</b>	6,01-10,50	107B01	*	107B11			
<b>I</b>	1,00-30,50	101111	*	103111		102111	*
<b>I/II</b>	30,51-38,00	1012M1	**			1022M1	**
<b>II</b>	30,51-40,00	101211		103211		102211	
	40,01-50,80	101221		103221		102221	
	50,81-60,00	101231		103231		102231	
	60,01-72,00	101241		103241		102241	
	72,01-76,20	101251		103251		102251	
<b>III</b>	76,21-105,00	101311				102311	
<b>reinforced version</b>	-30,50	108111		108311		108211	
	-40,00	108121		108321		108221	
	-76,20	1081-1		1083-1		1082-1	

\* Also for machine group „S“

\*\* Only for machine group „S“

\*\*\* Only for machine group „I“

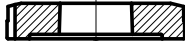

Stripper						
	Size	dim. "d" in mm	machine group	part.-no.	price	
	II	-78,00	-78,00	E / F	110211	
		-78,00	-78,00	A-D / G	111211	
		-78,00	-78,00	H / I	112211	
	III	-107,00	-107,00	E / G	110311	
-107,00		-107,00	C / D	111311		
(I/II)	-41,00	-41,00	S	1501M1		

Die						
	Size	dim. "d" in mm	HWS		HSS	
			part.-no.	price	part.-no.	price
	I	-32,00	106111	*	105111	*
	I/II	-32,00	1061M1	**	1051M1	**
	II	-77,00	106211		105211	**
	III	-107,00	106311			
	reinforced version	-32,00	109111	*		
		-42,00	109221			
-62,00		109231				

\* Also for machine group „S“  
\*\* Only for machine group „S“



Punch							
		HSS / Flat / 34,3 mm long		HSS / Flat / 37,8 mm long***		HSS / Whisper / 37,3 mm long	
Size	dim. "a" in mm	part.-no.	price	part.-no.	price	part.-no.	price
<b>0/A</b>	1,00-4,20	107A02	*	107A12			
<b>0/B</b> <small>(shaft 10,5)</small>	1,00-4,20	107C02	*	107C12			
<b>0/B</b>	4,21-7,40	107B02	*	107B12			
<b>I</b>	1,00-21,55	101112	*	103112		102112	*
<b>I/II</b>	21,56-26,85	1012M2	**			1022M2	**
<b>II</b>	21,56-28,25	101212		103212		102212	
	28,26-35,90	101222		103222		102222	
	35,91-42,40	101232		103232		102232	
	42,41-50,90	101242		103242		102242	
	50,91-53,90	101252		103252		102252	
<b>III</b>	53,91-74,25	101312				102312	
<b>reinforced version</b>	-21,55	108112		108312		108212	
	-28,25	108122		108322		108222	
	-53,90	1081-2		1083-2		1082-2	

Corner radius for square tools available on request. Surcharge: Punch +10%, Die +0%, Stripper +0%

\* Also for machine group „S“

\*\* Only for machine group „S“

\*\*\* Only for machine group „I“



### Stripper

	Size	dim. "a" in mm	machine group	part.-no.	price
	II	-56,00	E / F	110212	
		-56,00	A-D / G	111212	
		-56,00	H / I	112212	
	III	-77,00	E / G	110312	
-77,00		C / D	111312		
(I/II)	-30,00	S	1501M2		

### Die

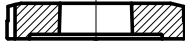
	Size	dim. "a" in mm	HWS		HSS	
			part.-no.	price	part.-no.	price
	I	-22,50	106112	*	105112	*
	I/II	-27,80	1061M2	**	1051M2	**
	II	-54,90	106212		105212	
	III	-75,50	106312			
	reinforced version	-23,50	109112	*		
		-30,20	109222			
-43,00		109232				

\* Also for machine group „S“

\*\* Only for machine group „S“



Punch							
		HSS / Flat/ 34,3 mm long		HSS / Flat/ 37,8 mm long***		HSS / Whisper/ 37,3 mm long	
Size	dim. "d" in mm	part.-no.	price	part.-no.	price	part.-no.	price
<b>0/A</b>	1,00-6,00	107A03	*	107A13			
<b>0/B</b> <small>(shaft 10,5)</small>	1,00-6,00	107C03	*	107C13			
<b>0/B</b>	6,01-10,50	107B03	*	107B13			
<b>I</b>	1,00-30,50	101113	*	103113		102113	*
<b>I/II</b>	30,51-38,00	1012M3	**			1022M3	**
<b>II</b>	30,51-40,00	101213		103213		102213	
	40,01-50,80	101223		103223		102223	
	50,81-60,00	101233		103233		102233	
	60,01-72,00	101243		103243		102243	
	72,01-76,20	101253		103253		102253	
<b>III</b>	76,21-105,00	101313				102313	
<b>reinforced version</b>	-30,50	108113		108313		108213	
	-40,00	108123		108323		108223	
	-76,20	1081-3		1083-3		1082-3	

Corner radius for square tools available on request. Surcharge: Punch +10%, Die +0%, Stripper +0%

\* Also for machine group „S“

\*\* Only for machine group „S“

\*\*\* Only for machine group „I“

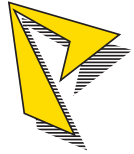

Stripper						
	Size	dim. "d" in mm	machine group	part.-no.	price	
	II	-78,00	-78,00	E / F	110213	
		-78,00	-78,00	A-D / G	111213	
		-78,00	-78,00	H / I	112213	
	III	-107,00	-107,00	E / G	110313	
-107,00		-107,00	C / D	111313		
(I/II)	-41,00	-41,00	S	1501M3		

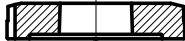
Die						
	Size	dim. "d" in mm	HWS		HSS	
			part.-no.	price	part.-no.	price
	I	-32,00	106113	*	105113	*
	I/II	-38,00	1061M3	**	1051M3	**
	II	-77,00	106213		105213	
	III	-107,00	106313			
	reinforced version	-32,50	109113	*		
		-42,00	109223			
-62,00		109233				

\* Also for machine group „S“  
\*\* Only for machine group „S“



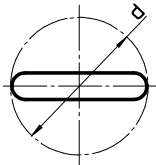
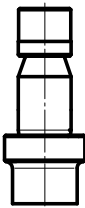
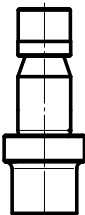
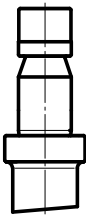

Punch							
		HSS / Flat / 34,3 mm long		HSS / Flat / 37,8 mm long***		HSS / Whisper / 37,3 mm long	
							
Size	dim. "d" in mm	part.-no.	price	part.-no.	price	part.-no.	price
<b>0/A</b>	1,00-6,00	107A04	*	107A14			
<b>0/B</b> <small>(shaft 10,5)</small>	1,00-6,00	107C04	*	107C14			
<b>0/B</b>	6,01-10,50	107B04	*	107B14			
<b>I</b>	1,00-30,50	101114	*	103114		102114	*
<b>I/II</b>	30,51-38,00	1012M4	**			1022M4	**
<b>II</b>	30,51-40,00	101214		103214		102214	
	40,01-50,80	101224		103224		102224	
	50,81-60,00	101234		103234		102234	
	60,01-72,00	101244		103244		102244	
	72,01-76,20	101254		103254		102254	
<b>III</b>	76,21-105,00	101314				102314	
<b>reinforced version</b>	-30,50	108114		108314		108214	
	-40,00	108124		108324		108224	
	-76,20	1081-4		1083-4		1082-4	

\* Also for machine group „S“

\*\* Only for machine group „S“

\*\*\* Only for machine group „I“

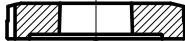

Stripper					
	Size	dim. "d" in mm	machine group	part.-no.	price
	II	-78,00	E / F	110214	
		-78,00	A-D / G	111214	
		-78,00	H / I	112214	
	III	-107,00	E / G	110314	
-107,00		C / D	111314		
(I/II)	-41,00	S	1501M4		

Die						
	Size	dim. "d" in mm	HWS		HSS	
			part.-no.	price	part.-no.	price
	I	-32,00	106114	*	105114	*
	I/II	-38,00	1061M4	**	1051M4	**
	II	-77,00	106214		105214	
	III	-107,00	106314			
	reinforced version	-32,50	109114	*		
		-42,00	109224			
-62,00		109234				

\* Also for machine group „S“  
\*\* Only for machine group „S“

# Catalog 12/05-T

Special Shape Tools

Group 1

(SF01, SF02, SF04, SF05)





System

# TRUMPF

## PASS STANZTECHNIK AG

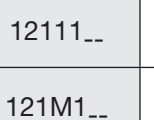
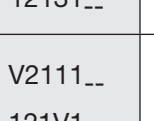

Am Steinkreuz 2  
 D 95473 Creußen  
 Phone: + 49 92 70 / 9 85 - 0  
 Fax: + 49 92 70 / 9 85 - 99  
 E-Mail: info@pass-ag.com  
 Internet: www.pass-ag.com

Punch							
		HSS / Flat / 34,3 mm long		HSS / Flat / 37,8 mm long***		HSS / Whisper / 37,3 mm long	
SF 01  SF 02  SF 04  SF 05  to complete part.-no.							
Size	dim. "d" in mm	part.-no.	price	part.-no.	price	part.-no.	price
<b>0/A</b>	1,00-6,00	121A0__	*	123A0__			
<b>0/B</b> <small>(shaft 10,5)</small>	1,00-6,00	121C0__	*	123C0__			
<b>0/B</b>	6,01-10,50	121B0__	*	123B0__			
<b>I</b>	1,00-30,50	12111__	*	12311__		12211__	*
<b>I/II</b>	30,51-38,00	121M1__	**			122M1__	**
<b>II</b>	30,51-40,00	12121__		12321__		12221__	
	40,01-50,80	12122__		12322__		12222__	
	50,81-60,00	12123__		12323__		12223__	
	60,01-72,00	12124__		12324__		12224__	
	72,01-76,20	12125__		12325__		12225__	
<b>III</b>	76,21-105,00	12131__				12231__	
<b>reinforced version</b>	-30,50	V2111__		V2311__		V2211__	
	-40,00	121V1__		123V1__		122V1__	
	-76,20	121V5__		123V5__		122V5__	

\* Also for machine group „S“

\*\* Only for machine group „S“

\*\*\* Only for machine group „I“

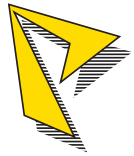

Stripper						
	Size	dim. "d" in mm	machine group	part.-no.	price	
	II		-78,00	E / F	12721..	
			-78,00	A-D / G	127D1..	
			-78,00	H / I	127H1..	
	III		-107,00	E / G	12731..	
		-107,00	C / D	1273D..		
(I/II)		-41,00	S	127M1..		

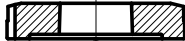
Die							
	Size	dim. "d" in mm	HWS		HSS		
			part.-no.	price	part.-no.	price	
	I	-32,00	12611..	*	12511..	*	
	I/II	-38,00	126M1..	**	125M1..	**	
	II	-77,00	12621..		12521..		
	III	-107,00	12631..				
	reinforced version		-32,50	V2611..	*		
			-42,00	126V1..			
		-62,00	126V2..				

SF 01

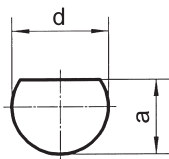

SF 02

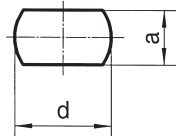

SF 04

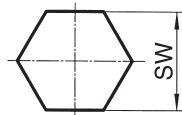

SF 05

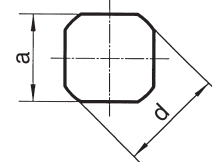

\* Also for machine group „S“

\*\* Only for machine group „S“

# Catalog 12/05-T

Special Shape Tools

Group 2

(SF03, SF07, SF13, SF17)

System

# TRUMPF

## PASS STANZTECHNIK AG



Am Steinkreuz 2





D 95473 Creußen

Phone: + 49 92 70 / 9 85 - 0

Fax: + 49 92 70 / 9 85 - 99

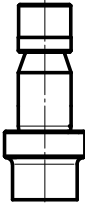
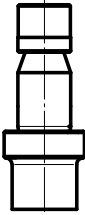
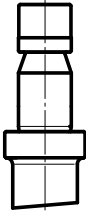
E-Mail: info@pass-ag.com

Internet: www.pass-ag.com

Punch							
		HSS / Flat / 34,3 mm long		HSS / Flat / 37,8 mm long***		HSS / Whisper / 37,3 mm long	
SF 03 							
SF 07 							
SF 13 							
SF 17  to complete part.-no.							
Size	dim. "d" in mm	part.-no.	price	part.-no.	price	part.-no.	price
<b>0/A</b>	1,00-6,00	121A0__	*	123A0__			
<b>0/B</b> <small>(shaft 10,5)</small>	1,00-6,00	121C0__	*	123C0__			
<b>0/B</b>	6,01-10,50	121B0__	*	123B0__			
<b>I</b>	1,00-30,50	12111__	*	12311__		12211__	*
<b>I/II</b>	30,51-38,00	121M1__	**			122M1__	**
<b>II</b>	30,51-40,00	12121__		12321__		12221__	
	40,01-50,80	12122__		12322__		12222__	
	50,81-60,00	12123__		12323__		12223__	
	60,01-72,00	12124__		12324__		12224__	
	72,01-76,20	12125__		12325__		12225__	
<b>III</b>	76,21-105,00	12131__				12231__	
<b>reinforced version</b>	-30,50	V2111__		V2311__		V2211__	
	-40,00	121V1__		123V1__		122V1__	
	-76,20	121V5__		123V5__		122V5__	

\* Also for machine group „S“

\*\* Only for machine group „S“

\*\*\* Only for machine group „I“



## Stripper

	Size	dim. "d" in mm	machine group	part.-no.	price	
	<b>II</b>		-78,00	E / F	12721..	
			-78,00	A-D / G	127D1..	
			-78,00	H / I	127H1..	
	<b>III</b>		-107,00	E / G	12731..	
		-107,00	C / D	1273D..		
<b>(I/II)</b>		-41,00	S	127M1..		

## Die

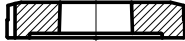
			HWS		HSS		
	Size	dim. "d" in mm	part.-no.	price	part.-no.	price	
	<b>I</b>		-32,00	12611..	*	12511..	*
	<b>I/II</b>		-38,00	126M1..	**	125M1..	**
	<b>II</b>		-77,00	12621..		12521..	
	<b>III</b>		-107,00	12631..			
	<b>reinforced version</b>		-32,50	V2611..	*		
			-42,00	126V1..			
		-62,00	126V2..				

**SF 03**

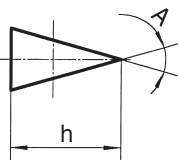

**SF 07**

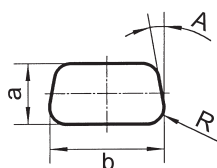

**SF 13**

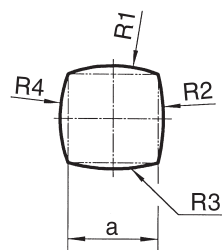

**SF 17**

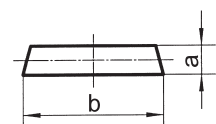

\* Also for machine group „S“

\*\* Only for machine group „S“

# Catalog 12/05-T

Special Shape Tools

Group 3

(SF06, SF08, SF14, SF16)

System

# TRUMPF

## PASS STANZTECHNIK AG



Am Steinkreuz 2





D 95473 Creußen

Phone: + 49 92 70 / 9 85 - 0

Fax: + 49 92 70 / 9 85 - 99

E-Mail: info@pass-ag.com

Internet: www.pass-ag.com

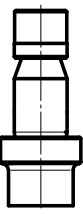
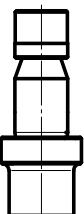
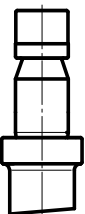
Punch							
		HSS / Flat / 34,3 mm long		HSS / Flat / 37,8 mm long***		HSS / Whisper / 37,3 mm long	
SF 06  SF 08  SF 14  SF 16  to complete part.-no.							
Size	dim. "d" in mm	part.-no.	price	part.-no.	price	part.-no.	price
<b>0/A</b>	1,00-6,00	121A0__	*	123A0__			
<b>0/B</b> <small>(shaft 10,5)</small>	1,00-6,00	121C0__	*	123C0__			
<b>0/B</b>	6,01-10,50	121B0__	*	123B0__			
<b>I</b>	1,00-30,50	12111__	*	12311__		12211__	*
<b>I/II</b>	30,51-38,00	121M1__	**			122M1__	**
<b>II</b>	30,51-40,00	12121__		12321__		12221__	
	40,01-50,80	12122__		12322__		12222__	
	50,81-60,00	12123__		12323__		12223__	
	60,01-72,00	12124__		12324__		12224__	
	72,01-76,20	12125__		12325__		12225__	
<b>III</b>	76,21-105,00	12131__				12231__	
<b>reinforced version</b>	-30,50	V2111__		V2311__		V2211__	
	-40,00	121V1__		123V1__		122V1__	
	-76,20	121V5__		123V5__		122V5__	

\* Also for machine group „S“

\*\* Only for machine group „S“

\*\*\* Only for machine group „I“

# Catalog 12/05-T

Special Shape Tools

Group 3

(SF06, SF08, SF14, SF16)

System

# TRUMPF

## PASS STANZTECHNIK AG

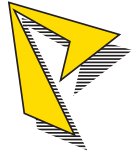

Am Steinkreuz 2

D 95473 Creußen

Phone: + 49 92 70 / 9 85 - 0

Fax: + 49 92 70 / 9 85 - 99

E-Mail: info@pass-ag.com

Internet: www.pass-ag.com

### Stripper

	Size	dim. "d" in mm	machine group	part.-no.	price
	II		-78,00	E / F	12721..
		-78,00	A-D / G	127D1..	
		-78,00	H / I	127H1..	
III		-107,00	E / G	12731..	
		-107,00	C / D	1273D..	
(I/II)		-41,00	S	127M1..	

### Die

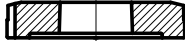
	Size	dim. "d" in mm	HWS		HSS		
			part.-no.	price	part.-no.	price	
	I	-32,00	12611..	*	12511..	*	
	I/II	-38,00	126M1..	**	125M1..	**	
	II	-77,00	12621..		12521..		
	III	-107,00	12631..				
	reinforced version		-32,50	V2611..	*		
			-42,00	126V1..			
		-62,00	126V2..				

SF 06

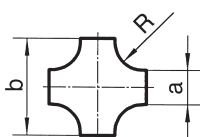

SF 08

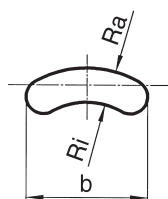

SF 14

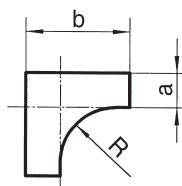

SF 16

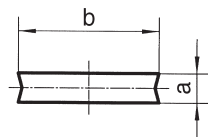

\* Also for machine group „S“

\*\* Only for machine group „S“



# Catalog 12/05-T

Special Shape Tools

Group 4

(SF09, SF10, SF11, SF12, SF15)

System

# TRUMPF

## PASS STANZTECHNIK AG



Am Steinkreuz 2





D 95473 Creußen

Phone: + 49 92 70 / 9 85 - 0

Fax: + 49 92 70 / 9 85 - 99

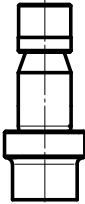
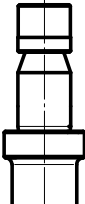
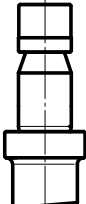
E-Mail: info@pass-ag.com

Internet: www.pass-ag.com

Punch							
		HSS / Flat/ 34,3 mm long		HSS / Flat/ 37,8 mm long***		HSS / Whisper/ 37,3 mm long	
SF 09							
SF 10							
SF 11							
SF 12							
SF 15							
to complete part.-no.							
Size	dim. "d" in mm	part.-no.	price	part.-no.	price	part.-no.	price
<b>0/A</b>	1,00-6,00	121A0__	*	123A0__			
<b>0/B</b> <small>(shaft 10,5)</small>	1,00-6,00	121C0__	*	123C0__			
<b>0/B</b>	6,01-10,50	121B0__	*	123B0__			
<b>I</b>	1,00-30,50	12111__	*	12311__		12211__	*
<b>I/ II</b>	30,51-38,00	121M1__	**			122M1__	**
<b>II</b>	30,51-40,00	12121__		12321__		12221__	
	40,01-50,80	12122__		12322__		12222__	
	50,81-60,00	12123__		12323__		12223__	
	60,01-72,00	12124__		12324__		12224__	
	72,01-76,20	12125__		12325__		12225__	
<b>III</b>	76,21-105,00	12131__				12231__	
<b>reinforced version</b>	-30,50	V2111__		V2311__		V2211__	
	-40,00	121V1__		123V1__		122V1__	
	-76,20	121V5__		123V5__		122V5__	

\* Also for machine group „S“

\*\* Only for machine group „S“

\*\*\* Only for machine group „I“

# Catalog 12/05-T

Special Shape Tools

Group 4

(SF 09, SF10, SF11, SF12, SF15)

System

# TRUMPF

## PASS STANZTECHNIK AG



Am Steinkreuz 2

D 95473 Creußen

Phone: + 49 92 70 / 9 85 - 0

Fax: + 49 92 70 / 9 85 - 99

E-Mail: info@pass-ag.com

Internet: www.pass-ag.com

### Stripper

	Size	dim. "d" in mm	machine group	part.-no.	price	
	II	-78,00	-78,00	E / F	12721..	
		-78,00	-78,00	A-D / G	127D1..	
		-78,00	-78,00	H / I	127H1..	
	III	-107,00	-107,00	E / G	12731..	
-107,00		-107,00	C / D	1273D..		
(I/II)	-41,00	-41,00	S	127M1..		

### Die

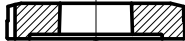
	Size	dim. "d" in mm	HWS		HSS	
			part.-no.	price	part.-no.	price
	I	-32,00	12611..	*	12511..	*
	I/II	-38,00	126M1..	**	125M1..	**
	II	-77,00	12621..		12521..	
	III	-107,00	12631..			
	reinforced version	-32,50	V2611..	*		
		-42,00	126V1..			
-62,00		126V2..				

SF 09

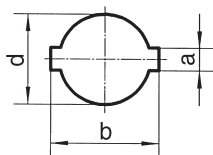

SF 10

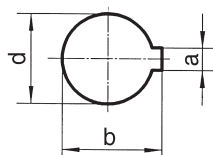

SF 11

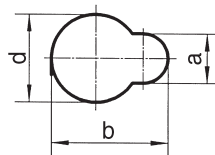

SF 12

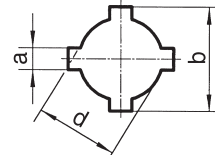

SF 15

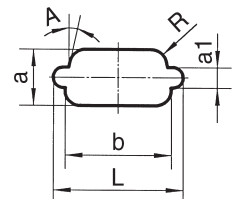

\* Also for machine group „S“

\*\* Only for machine group „S“



# Catalog 12/05-T

Fully guided round  
punch assemblies up to  
Ø 10,5 mm

System

## TRUMPF

# PASS STANZTECHNIK AG



Am Steinkreuz 2  
D 95473 Creußen  
Phone: + 49 92 70 / 9 85 - 0  
Fax: + 49 92 70 / 9 85 - 99  
E-Mail: info@pass-ag.com  
Internet: www.pass-ag.com

### Fully guided ROUND punch assemblies to Ø10,5mm (without die)

description	dim. "d" in mm	part.-no.	price	
complete upper part	0,50-6,00	1S160A	*	
complete upper part	6,01-10,50	1S160B	*	

### Spare parts for fully guided round punches

description	dim. "d" in mm	part.-no.	price	
punch insert / ASP 23	0,50-6,00	1S16SA	*	
punch insert / ASP 23	6,01-10,50	1S16SB	*	
spring	0,50-6,00	1S1608	*	
spring	6,01-10,50	1S1609	*	
guide	0,50-6,00	1S1603	*	
guide	6,01-10,50	1S1604	*	
lock nut	0,50-10,50	1S1607	*	

\* Also for machine group „S“

# Catalog 12/05-T

Fully guided shape  
punch assemblies for  
shapes that fit in  
Ø 16,0 mm circle

System

# TRUMPF

## PASS STANZTECHNIK AG

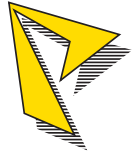

Am Steinkreuz 2  
D 95473 Creußen  
Phone: + 49 92 70 / 9 85 - 0  
Fax: + 49 92 70 / 9 85 - 99  
E-Mail: info@pass-ag.com  
Internet: www.pass-ag.com

### Fully guided SHAPE punch assemblies for shapes that fit in Ø16,0mm circle (without die)

shape	part.-no.	price
square	1S16502	
rectangular	1S16503	
oblong	1S16504	
special shape	1S16500	

### Spare punch (C101653) ASP 23

shape	part.-no.	price
square	1S16532	
rectangular	1S16533	
oblong	1S16534	
special shape	1S16530	

### Spare guide (C101656)

shape	part.-no.	price
square	1S16562	
rectangular	1S16563	
oblong	1S16564	
special shape	1S16560	

### Spare spring (C101654)

shape	part.-no.	price
usable for all shapes	1S16540	

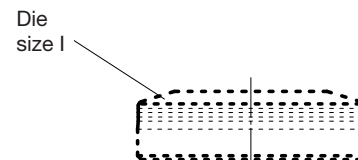
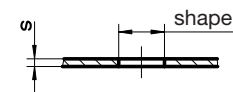
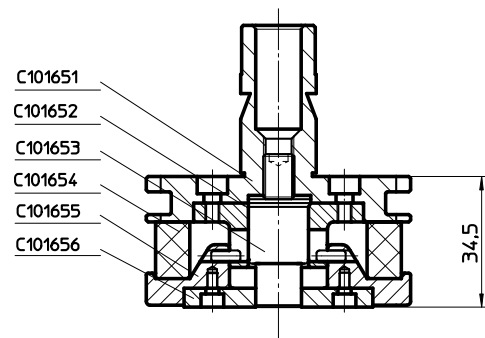



5- and 10-station Multitools



4- and 6-station Multitools



4- and 6-station Multitools (old version)





Am Steinkreuz 2  
D 95473 Creußen  
Phone: + 49 92 70 / 9 85 - 0  
Fax: + 49 92 70 / 9 85 - 99  
E-Mail: info@pass-ag.com  
Internet: www.pass-ag.com

Punch for 5-station-Multitool ***			
dim. "d" in mm	shape	part.-no.	price
1,00-16,00	round	113N31	
1,00-16,00	square	113N32	
1,00-16,00	rectangular	113N33	
1,00-16,00	oblong	113N34	

Die for 5-station-Multitool			
dim. "d" in mm	shape	part.-no.	price
-16,60	round	114031	
-16,60	square	114032	
-16,60	rectangular	114033	
-16,60	oblong	114034	

Shims for 5-station-Multitool Die		
	part.-no.	price per set
1 set consisting of: 2 pc. of t=0,1; 2 pc. of t=0,3; 2 pc. of t=0,5 mm	114U3M	

\*\*\* punches can be sharpened 0,2mm max.



Am Steinkreuz 2  
D 95473 Creußen  
Phone: + 49 92 70 / 9 85 - 0  
Fax: + 49 92 70 / 9 85 - 99  
E-Mail: info@pass-ag.com  
Internet: www.pass-ag.com

Punch for 10-station-Multitool ***			
dim. "d" in mm	shape	part.-no.	price
1,00-10,50	round	113N41	
1,00-10,50	square	113N42	
1,00-10,50	rectangular	113N43	
1,00-10,50	oblong	113N44	

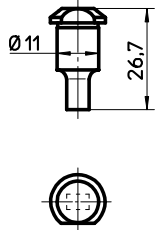

Die for 10-station-Multitool			
dim. "d" in mm	shape	part.-no.	price
-11,10	round	114041	
-11,10	square	114042	
-11,10	rectangular	114043	
-11,10	oblong	114044	
set of shims (2xt=0,1 / 2xt=0,3 / 2xt=0,5)		11404M	

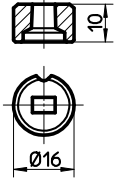

Die-Adapter for 10-station-Multitool Die			
dim. "d" in mm	shape	part.-no.	price
1,00-10,50	complete die adapter incl. 1 set of die shims	114Z40	

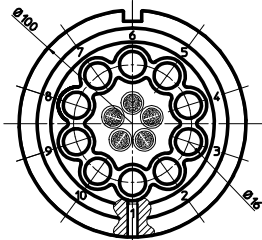

ALTERNATIVE 10-station-die			
dim. "d" in mm	shape	part.-no.	price
1,00-10,50	10-station die insert	114941	
	die adapter for 10-station die insert	114640	

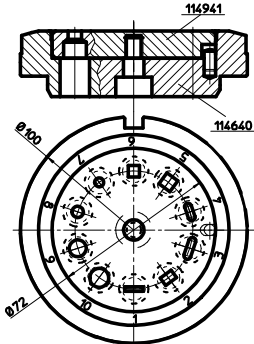

\*\*\* punches can be sharpened 0,2mm max.





Am Steinkreuz 2  
D 95473 Creußen  
Phone: + 49 92 70 / 9 85 - 0  
Fax: + 49 92 70 / 9 85 - 99  
E-Mail: info@pass-ag.com  
Internet: www.pass-ag.com

Punch for 4-station-Multitool ***			
dim. "d" in mm	shape	part.-no.	price
1,00-16,00	round	113N11	
1,00-16,00	square	113N12	
1,00-16,00	rectangular	113N13	
1,00-16,00	oblong	113N14	

Die for 4-station-Multitool			
dim. "d" in mm	shape	part.-no.	price
-16,60	round	114011	
-16,60	square	114012	
-16,60	rectangular	114013	
-16,60	oblong	114014	

Shims for 4-station-Multitool Die		
	part.-no.	price per set
1 set consisting of: 2 pc. of t=0,1; 2 pc. of t=0,3; 2 pc. of t=0,5 mm	114U1M	

\*\*\* punches can be sharpened 0,2mm max.



Am Steinkreuz 2  
D 95473 Creußen  
Phone: + 49 92 70 / 9 85 - 0  
Fax: + 49 92 70 / 9 85 - 99  
E-Mail: info@pass-ag.com  
Internet: www.pass-ag.com

Punch for 6-station-Multitool ***			
dim. "d" in mm	shape	part.-no.	price
1,00-10,50	round	113N21	
1,00-10,50	square	113N22	
1,00-10,50	rectangular	113N23	
1,00-10,50	oblong	113N24	

Die for 6-station-Multitool			
dim. "d" in mm	shape	part.-no.	price
-11,10	round	114021	
-11,10	square	114022	
-11,10	rectangular	114023	
-11,10	oblong	114024	

Shims for 6-station-Multitool Die		
1 set consisting of: 2 pc. of t=0,1; 2 pc. of t=0,3; 2 pc. of t=0,5 mm	part.-no.	price per Set
	114U2M	

\*\*\* punches can be sharpened 0,2mm max.



Am Steinkreuz 2  
D 95473 Creußen  
Phone: + 49 92 70 / 9 85 - 0  
Fax: + 49 92 70 / 9 85 - 99  
E-Mail: info@pass-ag.com  
Internet: www.pass-ag.com

Punch for 4-station-Multitool ***			
dim. "d" in mm	shape	part.-no.	price
1,00-16,00	round	113A11	
1,00-16,00	square	113A12	
1,00-16,00	rectangular	113A13	
1,00-16,00	oblong	113A14	

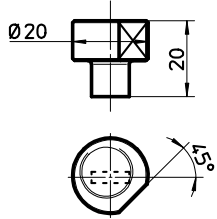

Die for 4-station-Multitool			
dim. "d" in mm	shape	part.-no.	price
-16,60	round	114011	
-16,60	square	114012	
-16,60	rectangular	114013	
-16,60	oblong	114014	

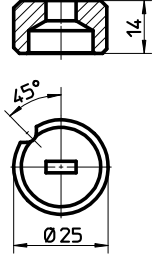

Shims for 4-station-Multitool Die		
	part.-no.	price per set
1 set consisting of: 2 pc. of t=0,1; 2 pc. of t=0,3; 2 pc. of t=0,5 mm	114U1M	

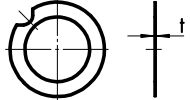

Shims for 4-station-Multitool punch		
	part.-no.	price per set
1 set consisting of: 2 pc. of t=0,1; 2 pc. of t=0,3; 2 pc. of t=0,5 mm	113U1S	

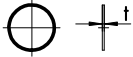

Threaded punch cap		
	part.-no.	price
	113010	

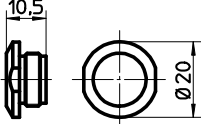

\*\*\* punches can be sharpened 2,0mm max. Adjust height by using of spacer washers 113U1S



Am Steinkreuz 2  
D 95473 Creußen  
Phone: + 49 92 70 / 9 85 - 0  
Fax: + 49 92 70 / 9 85 - 99  
E-Mail: info@pass-ag.com  
Internet: www.pass-ag.com

old version

Punch for 6-station-Multitool ***			
dim. "d" in mm	shape	part.-no.	price
1,00-10,50	round	113A21	
1,00-10,50	square	113A22	
1,00-10,50	rectangular	113A23	
1,00-10,50	oblong	113A24	

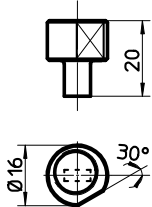

Die for 6-station-Multitool			
dim. "d" in mm	shape	part.-no.	price
-11,10	round	114021	
-11,10	square	114022	
-11,10	rectangular	114023	
-11,10	oblong	114024	

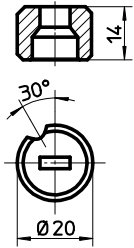

Shims for 6-station-Multitool Die		
1 set consisting of: 2 pc. of t=0,1; 2 pc. of t=0,3; 2 pc. of t=0,5 mm	part.-no.	price per set
	114U2M	

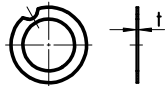

Shims for 6-station-Multitool punch		
1 set consisting of: 2 pc. of t=0,1; 2 pc. of t=0,3; 2 pc. of t=0,5 mm	part.-no.	price per set
	113U2S	

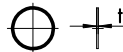

Threaded punch cap		
	part.-no.	price
	113020	

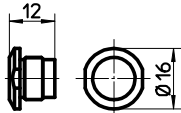

\*\*\* punches can be sharpened 2,0mm max. Adjust height by using of spacer washers 113U2S



Adjusting Rings and Accessories

Punch Chucks and Adapter Rings

Adjustment Device and Clamping Device for grinding the punches

Compensating Rings / Scratch less stickers / Spare Parts

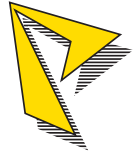

### Adjusting ring incl. key for automatic tool changers

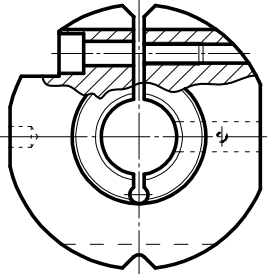
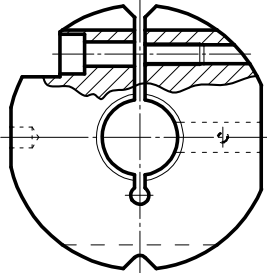
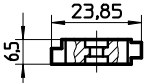
		size	machine group	part.-no.	price
	Adjusting ring incl. key	I	E-I	118101	
	Adjusting ring incl. key	II/III	E-I	118201	
	Adjusting key		E-I	118902	

### Adjusting ring incl. key for reinforced version punches

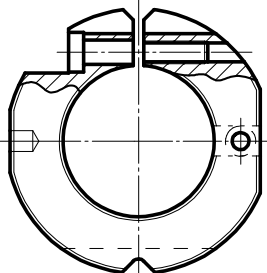
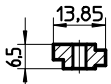
		size	machine group	part.-no.	price
	Adjusting ring incl. key	I/II	A-I	118V01	
	Adjusting key		A-I	118903	

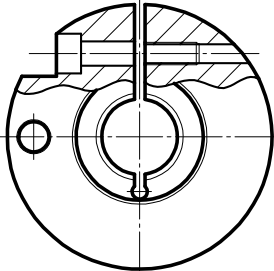
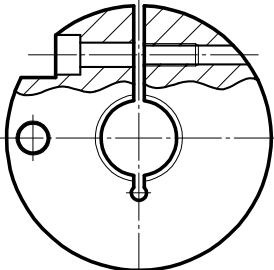
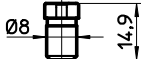

### Adjusting ring incl. bolt for manual tool change

		size	machine group	part.-no.	price
	Adjusting ring incl. bolt	I	A-D	118102	
	Adjusting ring incl. bolt	II/III	A-D	118202	
	Adjusting ring incl. bolt outside Ø 95	III	A-D	118302	
	Adjusting bolt		A-D	118901	

### Adjusting ring incl. key for automatic tool changers

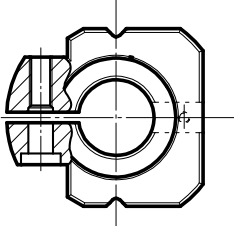
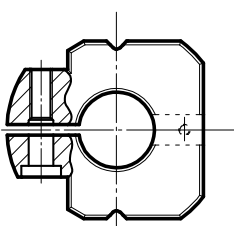
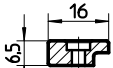
		size	machine group	part.-no.	price
	Adjusting ring incl. key	I	S	11820M	
	Adjusting ring incl. key	II	S	11810M	
	Adjusting key		S	118904	





### Punch Chuck

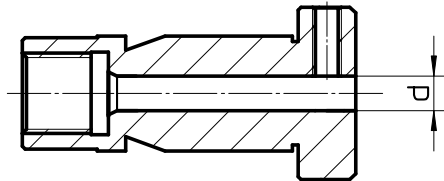

size	dim. "d"	part.-no.	price
0 A	6,00 mm	119A01	*
0 B	10,50 mm	119B01	*

### Adapter rings for strippers

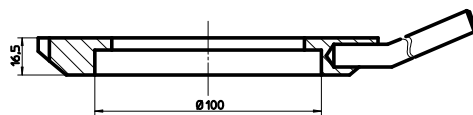
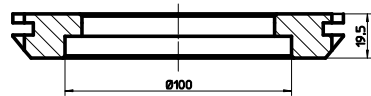

size	machine group	part.-no.	price
III/II	G	120321	
III/II	C/D	120326	

### Adapter rings for dies

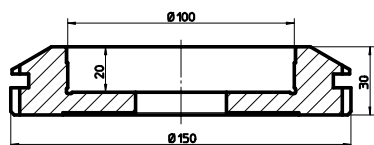
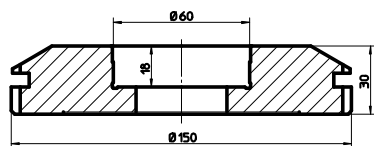
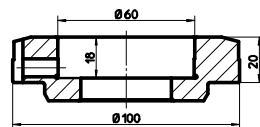

size	machine group	part.-no.	price
II/I	A, B, F, G, H, I	120210	
III/I	G	120310	
III/II	G	120320	

\*Also for machine group „S“

# Catalog 12/05-T

Adapter ring  
for die size II/I  
with brush-ring  
(for scratch-free parts)

System

## TRUMPF

### PASS STANZTECHNIK AG



Am Steinkreuz 2  
D 95473 Creußen  
Phone: + 49 92 70 / 9 85 - 0  
Fax: + 49 92 70 / 9 85 - 99  
E-Mail: info@pass-ag.com  
Internet: www.pass-ag.com



Adapter ring with brush				
size	machine group	part.-no.	price	
II/I	A, B, F, G, H, I	1S1820		

Spare brush for adapter ring				
size	machine group	part.-no.	price	
II/I	A, B, F, G, H, I	1S1822		

Spare shim rings for the brush insert				
size	machine group	part.-no.	price	
II/I	A, B, F, G, H, I	1S1823		<p>(1set = 6 piece)</p>

# Catalog 12/05-T

Adjustment device  
for punches

System

# TRUMPF

## PASS STANZTECHNIK AG



Am Steinkreuz 2  
D 95473 Creußen  
Phone: + 49 92 70 / 9 85 - 0  
Fax: + 49 92 70 / 9 85 - 99  
E-Mail: info@pass-ag.com  
Internet: www.pass-ag.com

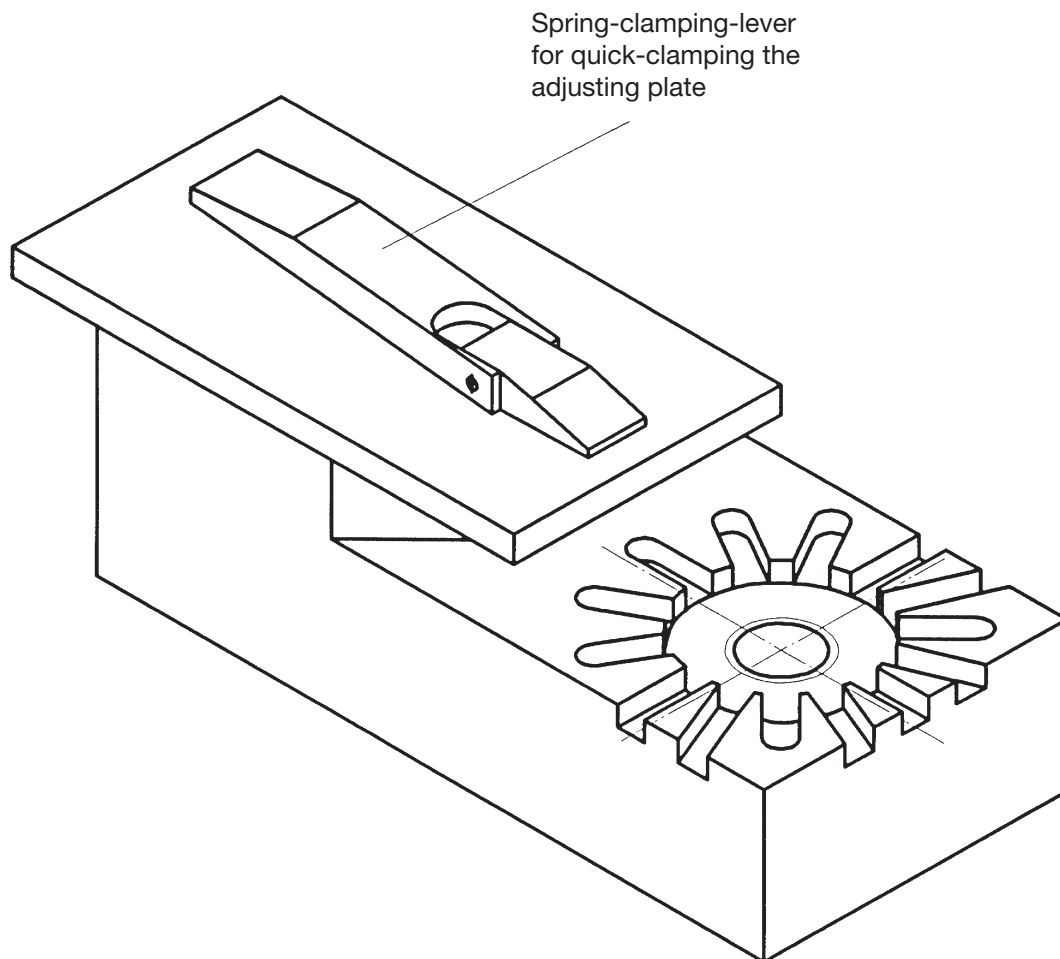

possible angles:

0° – 22,5° – 30° – 45° – 60° – 67,5° – 90°

part.-no.: Z 497673

# Catalog 12/05-T

Special vise  
for grinding the  
punches

System

# TRUMPF

## PASS STANZTECHNIK AG



Am Steinkreuz 2  
D 95473 Creußen  
Phone: + 49 92 70 / 9 85 - 0  
Fax: + 49 92 70 / 9 85 - 99  
E-Mail: info@pass-ag.com  
Internet: www.pass-ag.com

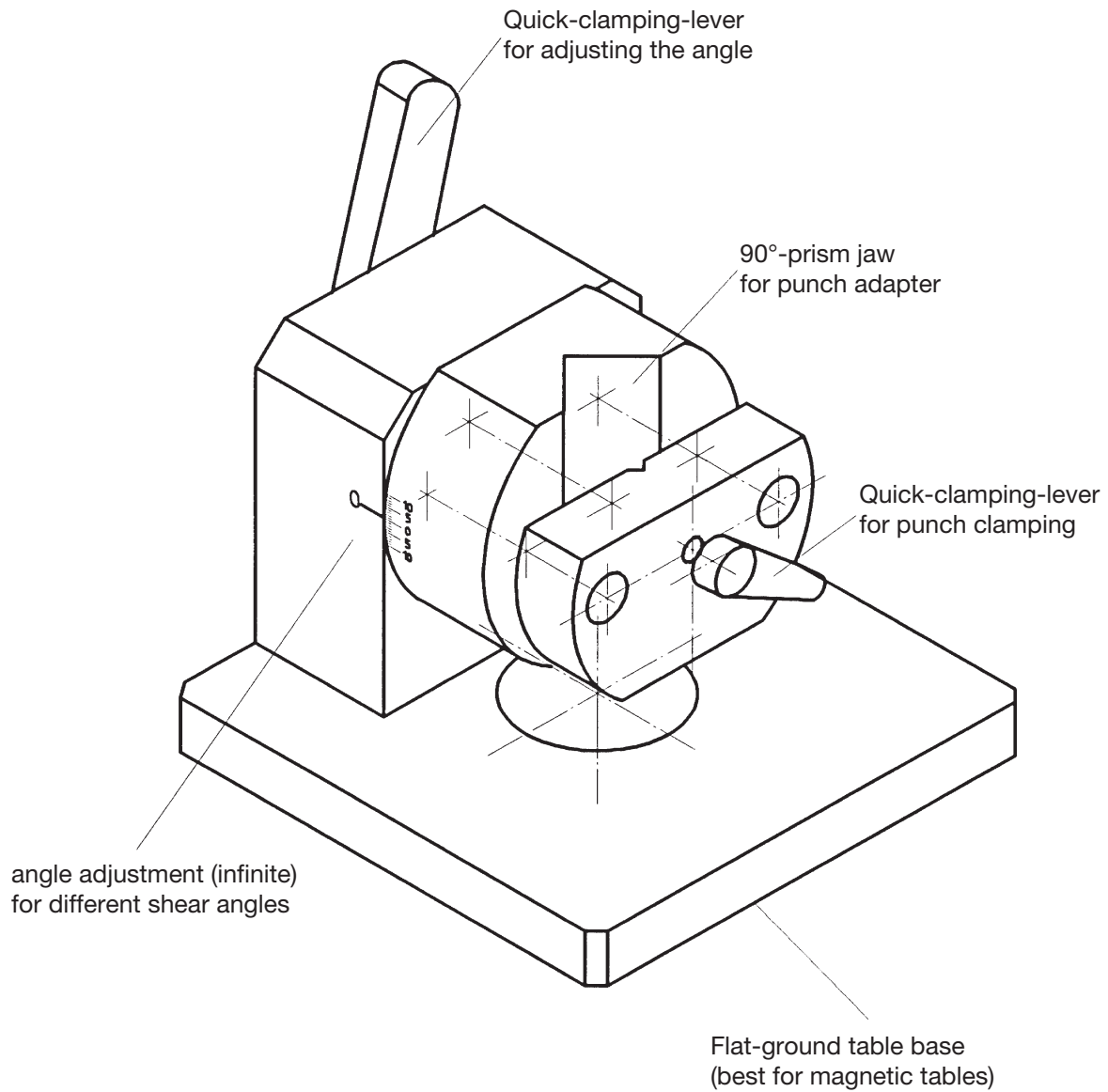

Useful for surface or profile grinders with magnetic tables

part.-no.: Z 496124

# Catalog 12/05-T

Compensating rings  
Scratch less stickers

System

## TRUMPF

### PASS STANZTECHNIK AG



Am Steinkreuz 2  
D 95473 Creußen  
Phone: + 49 92 70 / 9 85 - 0  
Fax: + 49 92 70 / 9 85 - 99  
E-Mail: info@pass-ag.com  
Internet: www.pass-ag.com

### Compensating rings for dies

size	measure "t"	part.-no.	price per set
I	1 set/6 pc 0,1 mm	11AS01	
	1 set/6 pc 0,3 mm	11AS03	
	1 set/6 pc 0,5 mm	11AS05	
	0,1 mm set : 2 x 0,3 mm 0,5 mm	11AS0_	
II	1 set/6 pc 0,1 mm	12AS01	
	1 set/6 pc 0,3 mm	12AS03	
	1 set/6 pc 0,5 mm	12AS05	
	0,1 mm set : 2 x 0,3 mm 0,5 mm	12AS0_	

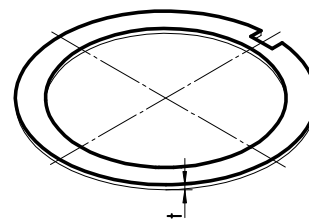

### Scratch less stickers for dies and strippers

description	size	part.-no.	price per piece
Die	I	PAD1M	
	II	PAD2M	
Stripper	II	PAD2A	

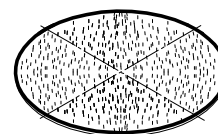



Am Steinkreuz 2  
D 95473 Creußen  
Phone: + 49 92 70 / 9 85 - 0  
Fax: + 49 92 70 / 9 85 - 99  
E-Mail: info@pass-ag.com  
Internet: www.pass-ag.com

System

**TRUMPF**

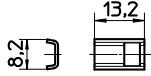
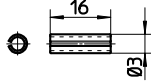
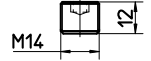
Spare Parts			
description	part.-no.	price	
Die clip	106991		
Stripper pin	110991		
Screw M14 x 1,5 x 12 for punch chuck	119991		





Slitting Tool 5 x 30



Slitting Tool 5 x 56



Slitting Tool 5 x 76,2



Slitting Tool 5 x 56  
with spring-loaded metal stripper for slittings close to forming



Slitting Tool 5 x 56  
with PU-stripper for slittings close to forming



Slitting Tool 5 x 76,2  
with PU-stripper for slittings close to forming



Slitting Tool 5 x 56  
with spring-loaded metal stripper (old version)



Reversible die plate system 5 x 30 / 5 x 56 / 5 x 76,2 (old version)



Slotting Tool 2,5 x 30,0 / 5,0 x 30,0

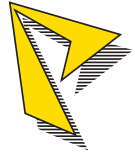

System

**TRUMPF**

Am Steinkreuz 2  
D 95473 Creußen  
Phone: + 49 92 70 / 9 85 - 0  
Fax: + 49 92 70 / 9 85 - 99  
E-Mail: info@pass-ag.com  
Internet: www.pass-ag.com

**Slitting Tool size II with integrated adjusting ring,  
slitting punch blade insert and die plate insert  
5 x 30**

type	part.-no.	price
with integrated adjusting ring, x-axis orientation (for all rotation machines) max. sheet thickness = 3 mm	1S04331_..	
with integrated adjusting ring, y-axis orientation max. sheet thickness = 3 mm		
without integrated adjusting ring, x- or y-axis orientation use adjusting ring 118V01 („accessories“ page 2) max. sheet thickness = 2,5 mm		

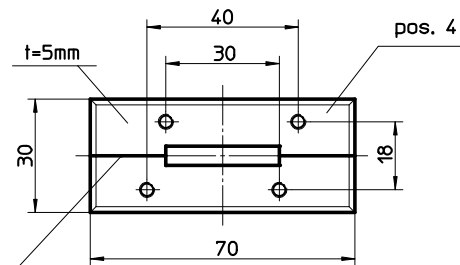
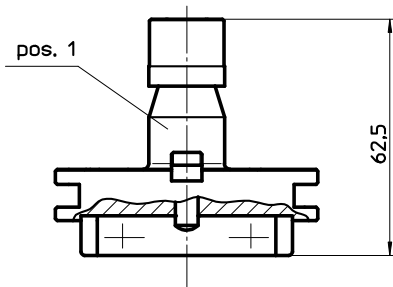

slitting die  
- splitted

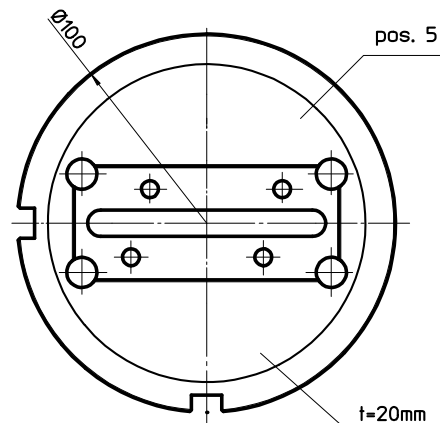
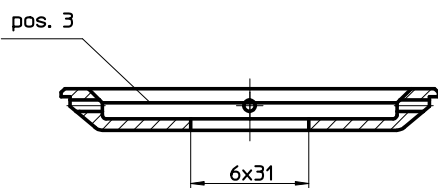
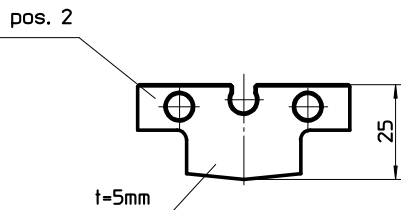

Standard orientation (for rotation machines) = 0° / x-axis







System

**TRUMPF**

Am Steinkreuz 2  
D 95473 Creußen  
Phone: + 49 92 70 / 9 85 - 0  
Fax: + 49 92 70 / 9 85 - 99  
E-Mail: info@pass-ag.com  
Internet: www.pass-ag.com

**Slitting tool size II with integrated adjusting ring,  
slitting punch blade insert and die plate insert  
5 x 30**

Description	 oblong	 rectangular	 rectangular with 4 x R = 0,5	 Microjoint (trapezoid)	 Microjoint (double trapezoid)
Tool complete pos. 1 - 5	1S0433110	1S0433120	1S0433130	1S0433140	1S0433150
Upper assy complete pos. 1 - 2	1S043311	1S043312	1S043313	1S043314	1S043315
Upper part pos. 1 (0°)	1S0393				
Slitting blade insert/HSS pos. 2	1S04331	1S04332	1S04333	1S04334	1S04335
Spare screw M8 x 16 (1set = 2 pce.)	1S0393Z				
Stripper pos. 3	119234	119233		119237	119236
Slitting die assy pos. 4 - 5	1S173010	1S173020		1S173040	1S173050
Slitting plate pos. 4	1S17251	1S17252		1S17254	1S17255
Slitting die adapter pos. 5	1S1730				

- Shim set for slitting die plate available: consisting of  
2 x 0,1 mm  
2 x 0,3 mm  
2 x 0,5 mm  
**part.-no. 1S3794**



System

# TRUMPF

Am Steinkreuz 2  
 D 95473 Creußen  
 Phone: + 49 92 70 / 9 85 - 0  
 Fax: + 49 92 70 / 9 85 - 99  
 E-Mail: info@pass-ag.com  
 Internet: www.pass-ag.com

### Slitting tool size II with integrated adjusting ring, slitting punch blade insert and die plate insert 5 x 56



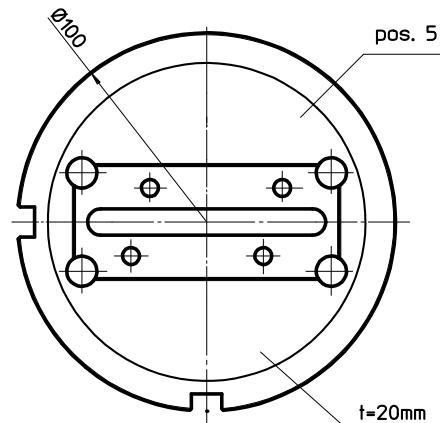
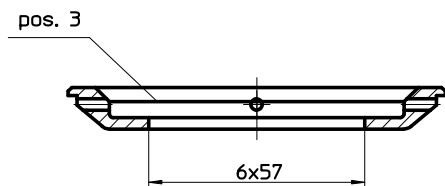
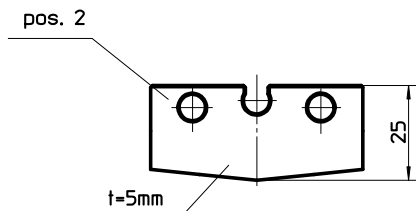
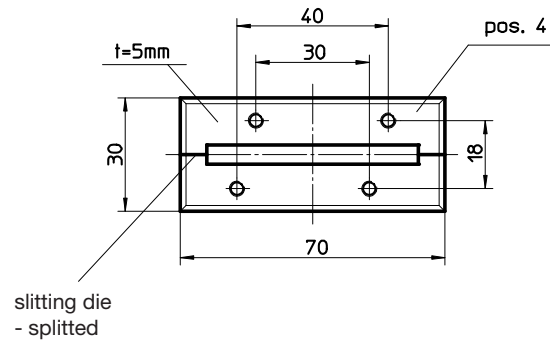
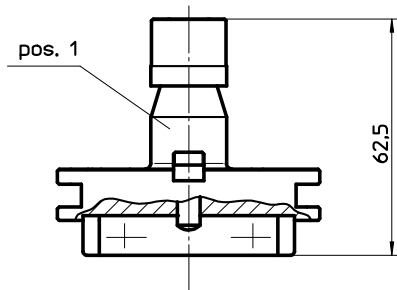

type	part.-no.	price
with integrated adjusting ring, x-axis orientation (for all rotation machines) max. sheet thickness = 3 mm	1S04311_..	
with integrated adjusting ring, y-axis orientation max. sheet thickness = 3 mm		
without integrated adjusting ring, x- or y-axis orientation use adjusting ring 118V01 („accessories“ page 2) max. sheet thickness = 2,5 mm		



Standard orientation (for rotation machines) = 0° / x-axis



### Slitting tool size II with integrated adjusting ring, slitting punch blade insert and die plate insert 5 x 56

Description	 oblong	 rectangular	 rectangular with 4 x R = 0,5	 Microjoint (trapezoid)	 Microjoint (double trapezoid)
Tool complete pos. 1 - 5	1S0431110	1S0431120	1S0431130	1S0431140	1S0431150
Upper assy complete pos. 1 - 2	1S043111	1S043112	1S043113	1S043114	1S043115
Upper part pos. 1 (0°)	1S0393				
Slitting blade insert/HSS pos. 2	1S04311	1S04312	1S04313	1S04314	1S04315
Spare screw M8 x 16 (1set = 2 pce.)	1S0393Z				
Stripper pos. 3	119254	119253		119257	119256
Slitting die assy pos. 4 - 5	1S175610	1S175620		1S175640	1S175650
Slitting plate pos. 4	1S17261	1S17262		1S17264	1S17265
Slitting die adapter pos. 5	1S1756				

- Shim set for slitting die plate available: consisting of  
 2 x 0,1 mm  
 2 x 0,3 mm  
 2 x 0,5 mm  
**part.-no. 1S3794**



System

**TRUMPF**

Am Steinkreuz 2  
D 95473 Creußen  
Phone: + 49 92 70 / 9 85 - 0  
Fax: + 49 92 70 / 9 85 - 99  
E-Mail: info@pass-ag.com  
Internet: www.pass-ag.com

**Slitting tool size II with integrated adjusting ring,  
slitting punch blade insert and die plate insert  
5 x 76,2**

type	part.-no.	price
with integrated adjusting ring, x-axis orientation (for all rotation machines) max. sheet thickness = 2,5 mm	1S04321..	
with integrated adjusting ring, y-axis orientation max. sheet thickness = 2,5 mm		
without integrated adjusting ring, x- or y-axis orientation use adjusting ring 118V01 („accessories“ page 2) max. sheet thickness = 2,0 mm		

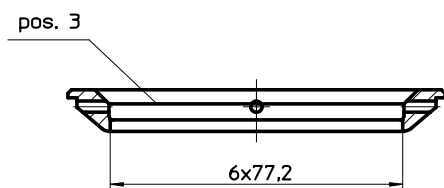
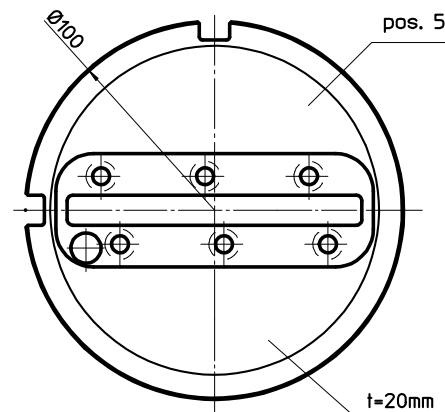
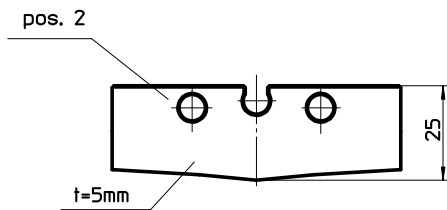
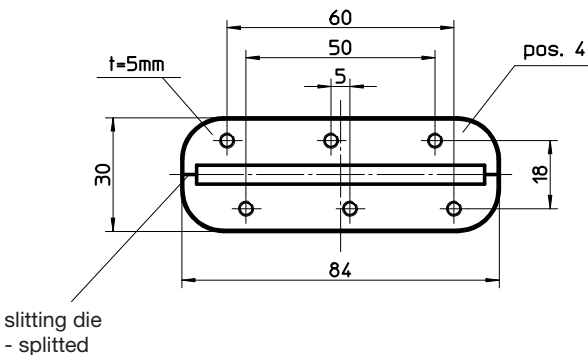
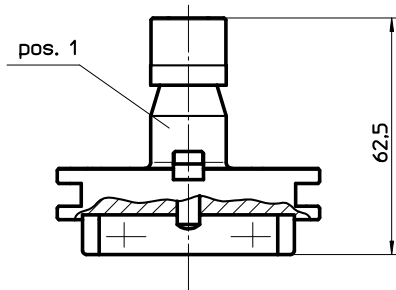

Standard orientation (for rotation machines) = 0° / x-axis

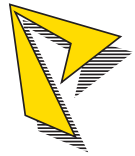





System

**TRUMPF**

Am Steinkreuz 2  
D 95473 Creußen  
Phone: + 49 92 70 / 9 85 - 0  
Fax: + 49 92 70 / 9 85 - 99  
E-Mail: info@pass-ag.com  
Internet: www.pass-ag.com

**Slitting tool size II with integrated adjusting ring,  
slitting punch blade insert and die plate insert  
5 x 76,2**

Description	 oblong	 rectangular	 rectangular with 4 x R = 0,5	 Microjoint (trapezoid)	 Microjoint (double trapezoid)
Tool complete pos. 1 - 5	1S0432110	1S0432120	1S0432130	1S0432140	1S0432150
Upper assy complete pos. 1 - 2	1S043211	1S043212	1S043213	1S043214	1S043215
Upper part pos. 1 (0°)	1S0393				
Slitting blade insert/HSS pos. 2	1S04321	1S04322	1S04323	1S04324	1S04325
Spare screw M8 x 16 (1set = 2 pce.)	1S0393Z				
Stripper pos. 3	119274	119273		119277	119276
Slitting die assy pos. 4 - 5	1S177610	1S177620		1S177640	1S177650
Slitting plate pos. 4	1S17411	1S17412		1S17414	1S17415
Slitting die adapter pos. 5	1S1776				

- Shim set for slitting die plate available: consisting of  
2 x 0,1 mm  
2 x 0,3 mm  
2 x 0,5 mm  
**part.-no. 1S3797**

# Catalog 12/05-T

## Slitting-Tool 5 x 56

- spring-loaded metal stripper
- for slitting close to forming until  $H = 4,5 \text{ mm}$

System

# TRUMPF

## PASS STANZTECHNIK AG



Am Steinkreuz 2  
D 95473 Creußen  
Phone: + 49 92 70 / 9 85 - 0  
Fax: + 49 92 70 / 9 85 - 99  
E-Mail: info@pass-ag.com  
Internet: www.pass-ag.com

### Slitting tool size II with integrated adjusting ring, for slittings close to forming 5 x 56

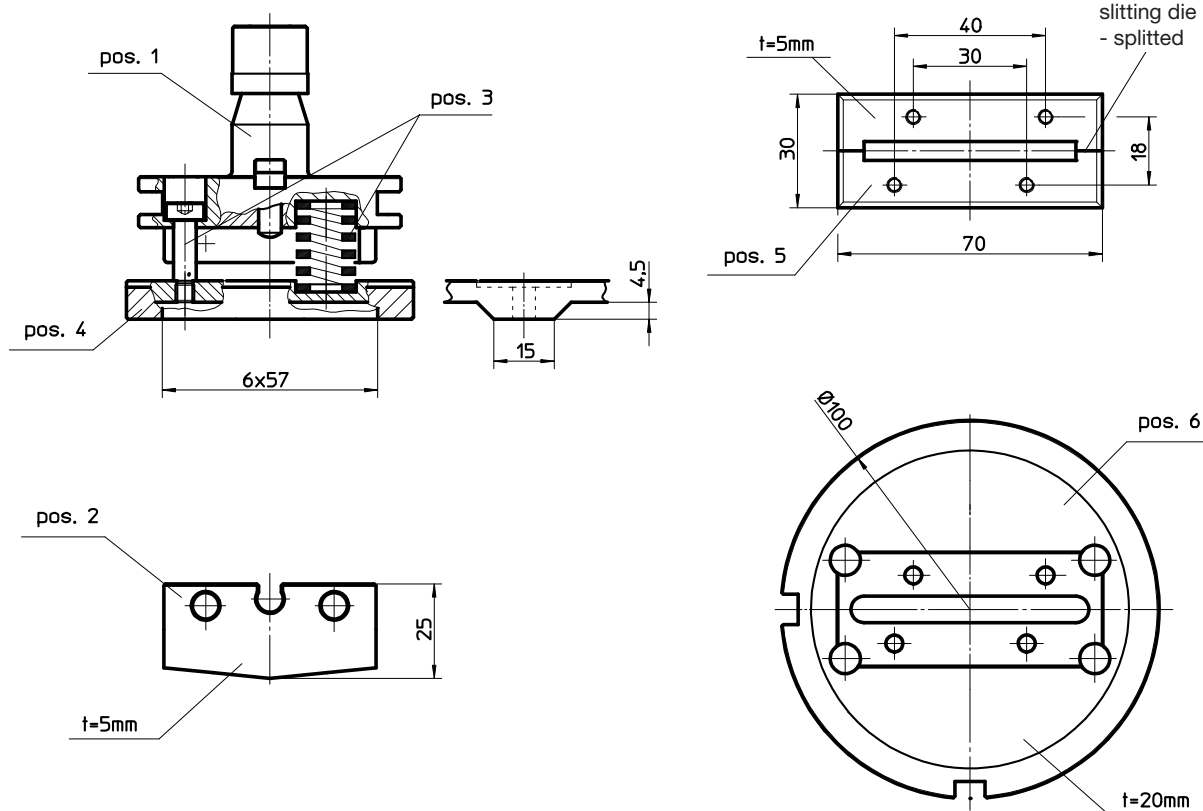

Standard orientation (for rotation machines) =  $0^\circ$  / x-axis

# Catalog 12/05-T

## Slitting Tool 5 x 56

- spring-loaded metal stripper
- for slitting close to forming until H = 4,5 mm

System





# TRUMPF

## PASS STANZTECHNIK AG



Am Steinkreuz 2  
D 95473 Creußen  
Phone: + 49 92 70 / 9 85 - 0  
Fax: + 49 92 70 / 9 85 - 99  
E-Mail: info@pass-ag.com  
Internet: www.pass-ag.com

### Slitting tool size II with integrated adjusting ring, for slittings close to forming 5 x 56

Description	 oblong	 rectangular	 rectangular with 4 x R = 0,5	 Microjoint (trapezoid)	 Microjoint (double trapezoid)
Tool complete pos. 1 - 6	1S037110	1S037120	1S037130	1S037140	1S037150
Upper assy complete pos. 1 - 4	1S03711	1S03712	1S03713	1S03714	1S03715
Upper part pos. 1 (0°)	1S0371				
Slitting blade insert/HSS pos. 2	1S04311	1S04312	1S04313	1S04314	1S04315
Set Spare Springs and Screws pos. 3	1S0379				
Active Stripper pos. 4	1S03751	1S03752	1S03753	1S03754	1S03755
Slitting die assy pos. 5 - 6	1S175610	1S175620		1S175640	1S175650
Slitting plate pos. 5	1S17261	1S17262		1S17264	1S17265
Slitting die adapter pos. 6	1S1756				

- max. sheet thickness = 1,5 mm

5 x 56



# Catalog 12/05-T

Slitting Tool 5 x 56  
- for slitting close to forming  
- with PU-stripper

System

## TRUMPF

### PASS STANZTECHNIK AG

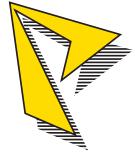

Am Steinkreuz 2  
D 95473 Creußen  
Phone: + 49 92 70 / 9 85 - 0  
Fax: + 49 92 70 / 9 85 - 99  
E-Mail: info@pass-ag.com  
Internet: www.pass-ag.com

### Slitting tool size II with PU-stripper for slitting close to forming 5 x 56

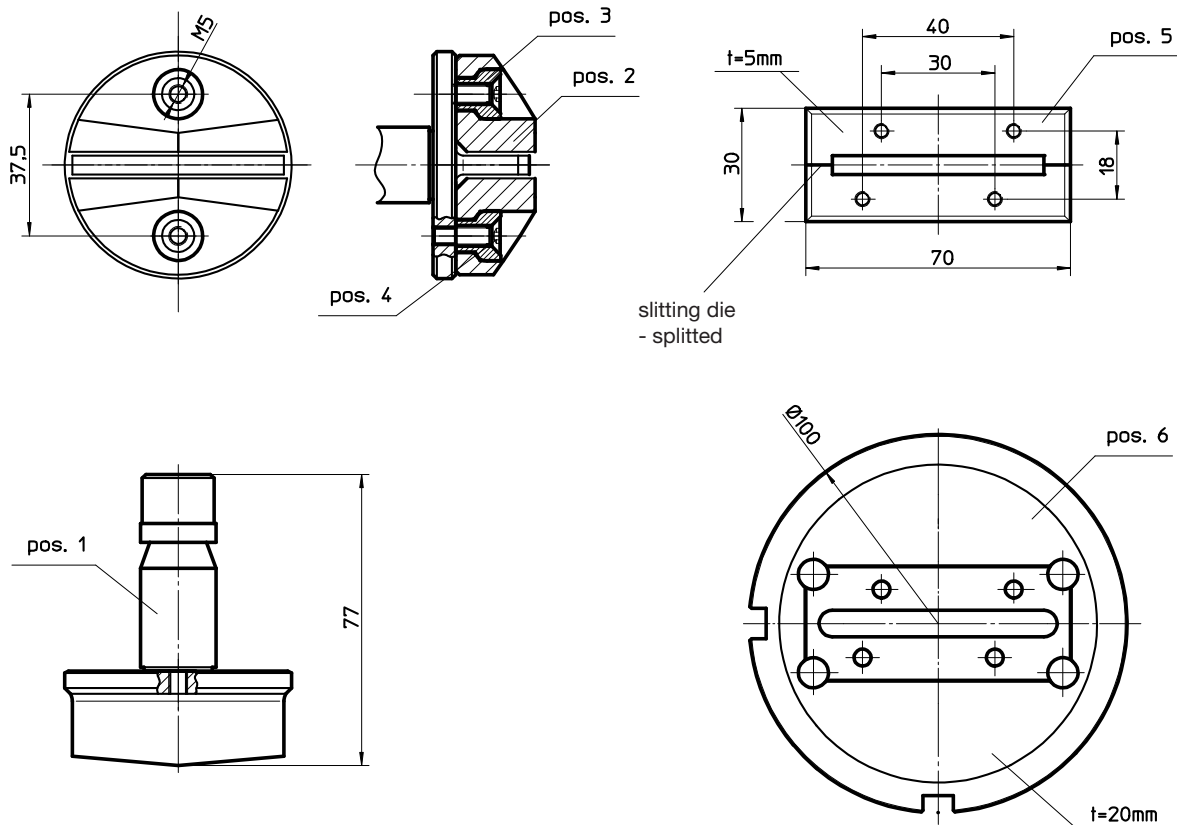

# Catalog 12/05-T

**Slitting Tool 5 x 56**  
 - for slitting close to forming  
 - with PU-stripper

System





## TRUMPF

## PASS STANZTECHNIK AG



Am Steinkreuz 2  
 D 95473 Creußen  
 Phone: + 49 92 70 / 9 85 - 0  
 Fax: + 49 92 70 / 9 85 - 99  
 E-Mail: info@pass-ag.com  
 Internet: www.pass-ag.com

### Slitting tool size II with PU-stripper for slitting close to forming 5 x 56

Description	 oblong	 rectangular	 rectangular with 4 x R = 0,5	 Microjoint (trapezoid)	 Microjoint (double trapezoid)
Tool complete pos. 1 - 6	1S295010	1S295020	1S295030	1S295040	1S295050
Upper assy complete pos. 1 - 4	1S29501	1S29502	1S29503	1S29504	1S29505
Punch pos. 1	1S29511	1S29512	1S29513	1S29514	1S29515
Set of PU-Springs pos. 2	1S2956				
Set of bushing pos. 3	1S2954				
Set of screws pos. 4	1S2950				
Slitting die assy pos. 5 - 6	1S175610	1S175620		1S175640	1S175650
Slitting plate pos. 5	1S17261	1S17262		1S17264	1S17265
Slitting die adapter pos. 6	1S1756				

- max. sheet thickness = 3 mm

5 x 56  



# Catalog 12/05-T

Slitting Tool 5 x 76,2  
- for slitting close to forming  
- with PU-stripper

System

# TRUMPF

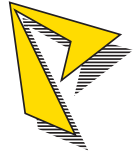
## PASS STANZTECHNIK AG



Am Steinkreuz 2  
D 95473 Creußen  
Phone: + 49 92 70 / 9 85 - 0  
Fax: + 49 92 70 / 9 85 - 99  
E-Mail: info@pass-ag.com  
Internet: www.pass-ag.com

### Slitting tool size II with PU-stripper for slitting close to forming 5 x 76,2

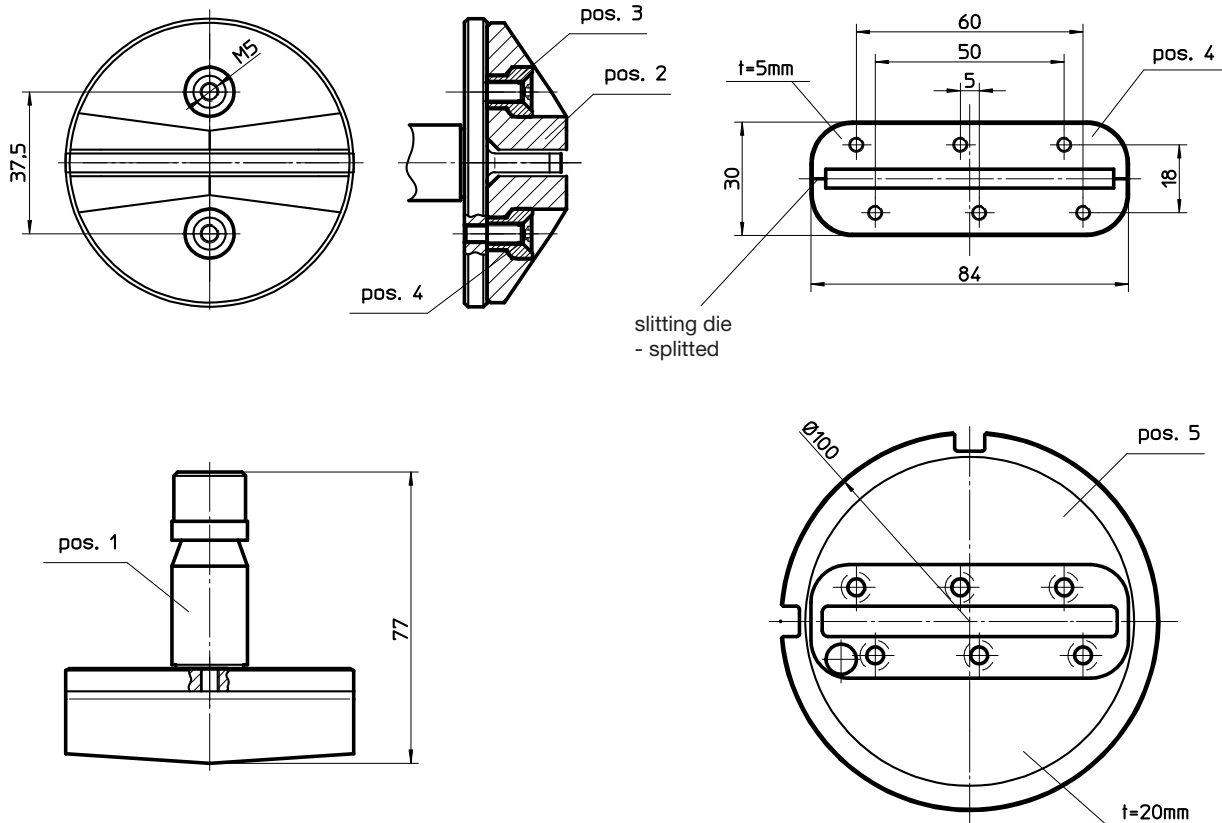

# Catalog 12/05-T

Slitting Tool 5 x 76,2  
 - for slitting close to forming  
 - with PU-stripper

System





## TRUMPF

### PASS STANZTECHNIK AG



Am Steinkreuz 2  
 D 95473 Creußen  
 Phone: + 49 92 70 / 9 85 - 0  
 Fax: + 49 92 70 / 9 85 - 99  
 E-Mail: info@pass-ag.com  
 Internet: www.pass-ag.com

### Slitting tool size II with PU-stripper for slitting close to forming 5 x 76,2

Description	 oblong	 rectangular	 rectangular with 4 x R = 0,5	 Microjoint (trapezoid)	 Microjoint (double trapezoid)
Tool complete pos. 1 - 6	1S297010	1S297020	1S297030	1S297040	1S297050
Upper assy complete pos. 1 - 4	1S29701	1S29702	1S29703	1S29704	1S29705
Punch pos. 1	1S29711	1S29712	1S29713	1S29714	1S29715
Set PU-Springs pos. 2	1S2955				
Set Bushing pos. 3	1S2954				
Set Screws pos. 4	1S2950				
Slitting die assy pos. 5 - 6	1S177610	1S177620		1S177640	1S177650
Slitting plate pos. 5	1S17411	1S17412		1S17414	1S17415
Slitting die adapter pos. 6	1S1776				

- max. sheet thickness = 2,5 mm

5 x 76,2

# Catalog 12/05-T

Slitting Tool upper parts  
and Spare parts  
for old versions

System

# TRUMPF

## PASS STANZTECHNIK AG



Am Steinkreuz 2  
D 95473 Creußen  
Phone: + 49 92 70 / 9 85 - 0  
Fax: + 49 92 70 / 9 85 - 99  
E-Mail: info@pass-ag.com  
Internet: www.pass-ag.com

### Slitting Tool size II with spring-loaded stripper old versions

#### Type A

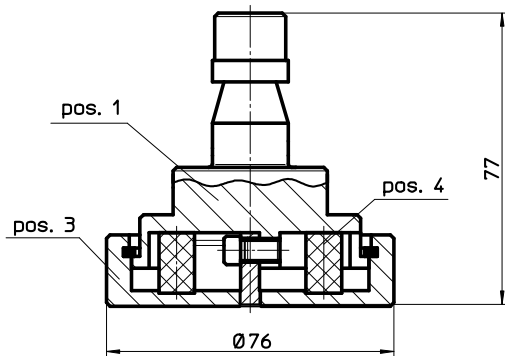

max. sheet thickness  
= 2,5 mm

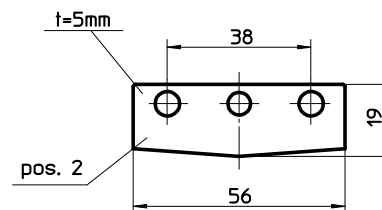

#### Type B

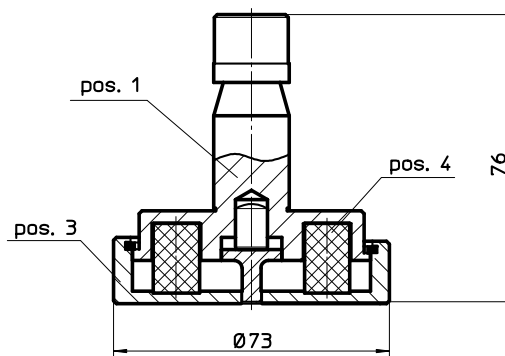

max. sheet thickness  
= 3 mm

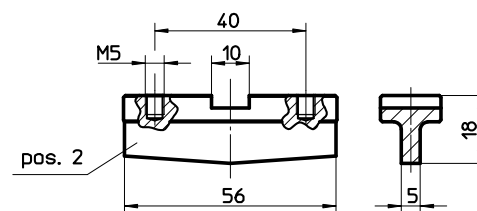

part. 1S0421\_

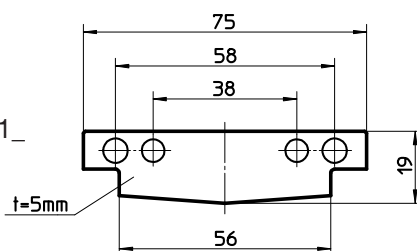



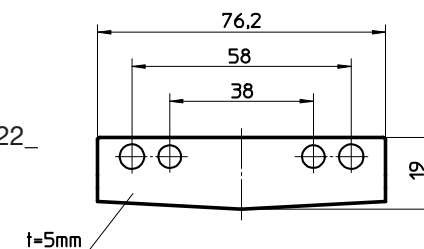

part. 1S0422\_





**Slitting tool size II  
with spring-loaded stripper  
old versions**

Description	 oblong	 rectangular	 rectangular with 4 x R = 0,5	 Microjoint (trapezoid)	 Microjoint (double trapezoid)
Upper assy complete Type A pos. 1 - 4	1S03001	1S03002	1S03003	1S03004	1S03005
Slitting blade insert/HSS pos. 2	1S04011	1S04012	1S04013	1S04014	1S04015
Active stripper pos. 3	1S03031	1S03032	1S03033	1S03034	1S03035
Locking ring	1S030094				
Upper assy complete Type B pos. 1 - 4	1S03401	1S03402	1S03403	1S03404	1S03405
Slitting blade insert/HSS pos. 2	1S04511	1S04512	1S04513	1S04514	1S04515
Active stripper pos. 3	1S03431	1S03432	1S03433	1S03434	1S03435
Locking ring	1S034094				
Slitting blade insert/HSS part.-no. 1S0421_	1S04211	1S04212	1S04213	1S04214	1S04215
Slitting blade insert/HSS part.-no. 1S0422_	1S04221	1S04222	1S04223	1S04224	1S04225



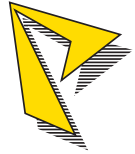

**Reversible plate systems size II  
old versions**

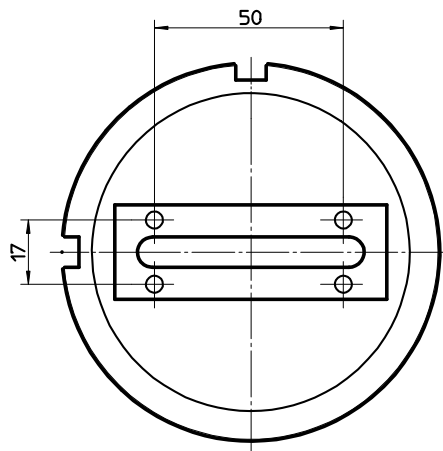

part. 1S1751

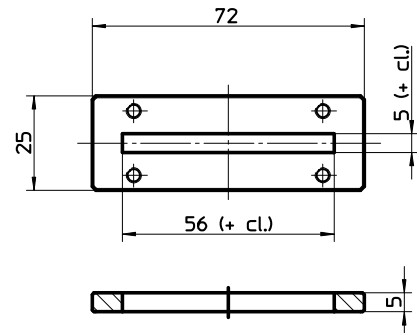
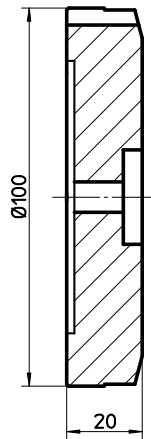

part. 1S1701\_

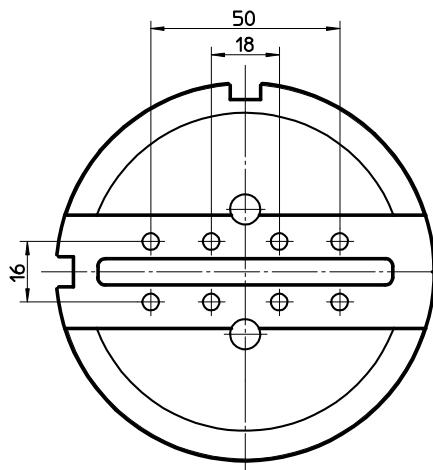

part. 1S1760

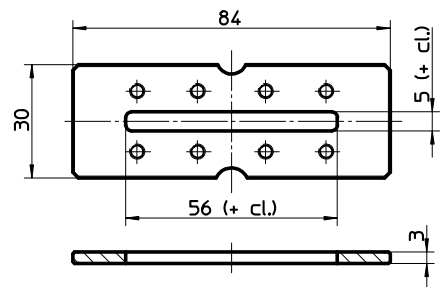
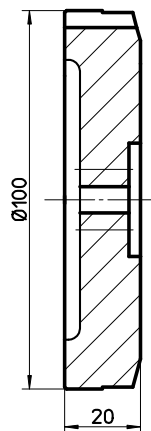

part. 1S1711\_

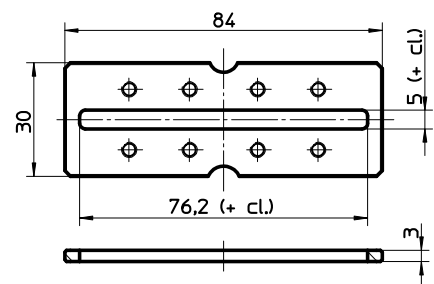

part. 1S1710\_

# Catalog 12/05-T

Slitting dies  
with reversible plates  
for old versions

System



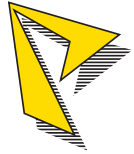

## TRUMPF

### PASS STANZTECHNIK AG



Am Steinkreuz 2  
D 95473 Creußen  
Phone: + 49 92 70 / 9 85 - 0  
Fax: + 49 92 70 / 9 85 - 99  
E-Mail: info@pass-ag.com  
Internet: www.pass-ag.com

### Reversible plate systems size II old versions

Description					
	oblong	rectangular	rectangular with 4 x R = 0,5	Microjoint (trapezoid)	Microjoint (double trapezoid)
Reversible plate adapter	1S1751				
Reversible plate 5 x 56 part.-no. 1S1701_	1S17011	1S17012	1S17013	1S17014	1S17015
Shim set (2 x 0,1; 2 x 0,3; 2 x 0,5)	1S3770				
Reversible plate adapter	1S1760				
Reversible plate 5 x 56 part.-no. 1S1711_	1S17111	1S17112	1S17113	1S17114	1S17115
Reversible plate 5 x 76,2 part.-no. 1S1710_	1S17101	1S17102	1S17103	1S17104	1S17105
Shim set (2 x 0,1; 2 x 0,3; 2 x 0,5)	1S3785				

5x56  
5x76,2







System

**TRUMPF**

Am Steinkreuz 2  
D 95473 Creußen  
Phone: + 49 92 70 / 9 85 - 0  
Fax: + 49 92 70 / 9 85 - 99  
E-Mail: info@pass-ag.com  
Internet: www.pass-ag.com

**Slotting tool**  
**2,5x30,0 / 5,0x30,0**

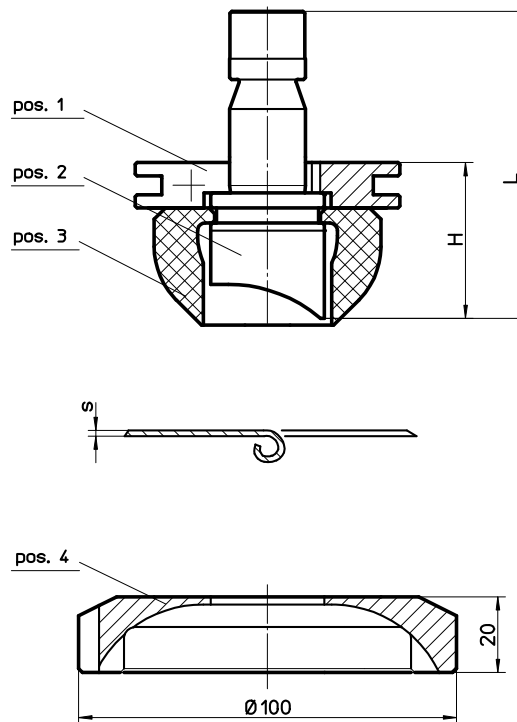

The maximum slitting length depends on the sheet thickness.

Directions: s = 0,5 ----- 2000 mm  
s = 0,8 ----- 1500 mm  
s = 1,0 ----- 1200 mm  
s = 1,5 ----- 750 mm  
s = 2,0 ----- 550 mm  
s = 2,5 ----- 400 mm  
s = 3,0 ----- 300 mm



System

**TRUMPF**

Am Steinkreuz 2  
D 95473 Creußen  
Phone: + 49 92 70 / 9 85 - 0  
Fax: + 49 92 70 / 9 85 - 99  
E-Mail: info@pass-ag.com  
Internet: www.pass-ag.com

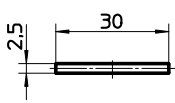
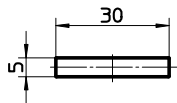
Slotting tool 2,5x30,0 / 5,0x30,0		
<b>Description</b>	 rectangular 2,5 x 30,0	 rectangular 5,0 x 30,0
Tool complete pos. 1 - 4	1S350W25	1S350W50
Upper assy complete pos. 1 - 3	1S350025	1S350050
Adjusting ring pos. 1	118101	118101
Punch pos. 2	1S350125	1S350150
PU-Spring pos. 3	1S350225	1S350250
Die size II pos. 4	1S350325	1S350350



PASS-FIT-System  
Explanation and Surcharges

---

---

PASS-FIT-System  
Adjusting rings

---

---

PASS-FIT-System  
Square Punches

---

---

PASS-FIT-System  
Rectangle - and Oblong Punches

---

---

PASS-FIT-System  
Grind Punches

---

---

PASS-FIT-System  
EDM Punches

---

---

---

---

---

---

---

---

---

---

---

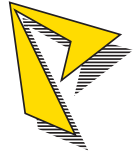

System

**TRUMPF**

Am Steinkreuz 2  
D 95473 Creußen  
Phone: + 49 92 70 / 9 85 - 0  
Fax: + 49 92 70 / 9 85 - 99  
E-Mail: [info@pass-ag.com](mailto:info@pass-ag.com)  
Internet: [www.pass-ag.com](http://www.pass-ag.com)

## **PASS - FIT - System**

**for fast and easy adjustment without the need for a fixture**



- high operational security, preventing expensive tool misalignments
- clearance free assembly
- easy quick and easy assembly for asymmetrical shape tools
- highly recommended on tough materials like thick stainless. The punch shaft is intact (without any grooves or holes)
- standard on PASS cluster and shaped forming tools. Optional on all other tools
- utilizes a fixed pin for reliable and precise alignment

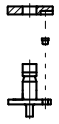

System

**TRUMPF**

Am Steinkreuz 2  
D 95473 Creußen  
Phone: + 49 92 70 / 9 85 - 0  
Fax: + 49 92 70 / 9 85 - 99  
E-Mail: info@pass-ag.com  
Internet: www.pass-ag.com

**PASS-FIT-System**

- for quick alignment without the need for special tools or fixtures
- special keyways on customer request
- PASS forming tools are generally manufactured with PASS-FIT-System

**size I\***

**size II/III\***

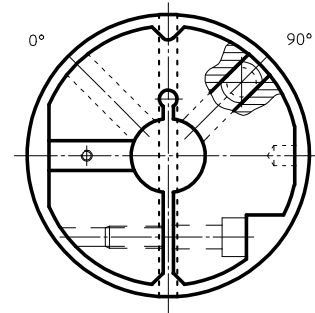
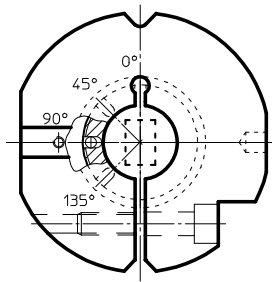
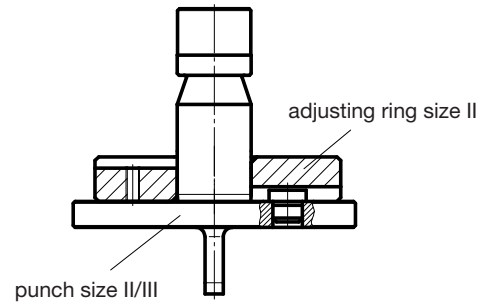
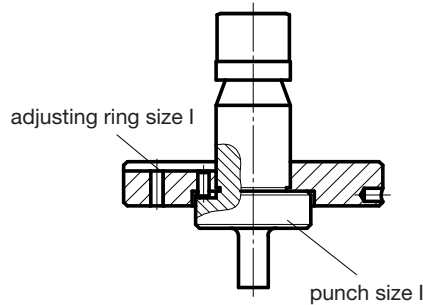

to complete part.-no.

----P1

----P2

**surcharges for punches**

first groove :  
each additional groove :

first alignment hole & pin (at 0° + 90°) :  
each additional hole :

\* Also for machine group „S“

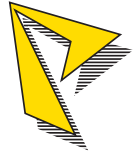

**PASS-FIT-Adjusting ring incl. key for automatic tool changers**

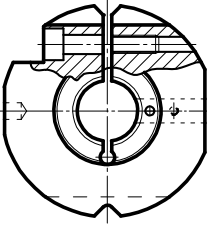
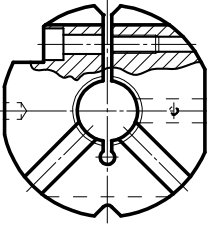
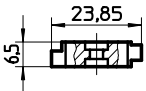
		size	machine group	part.-no.	price
	Adjusting ring incl. key	I	E-I	1181P1	
	Adjusting ring incl. key	II/III	E-I	1182P1	
	Adjusting key		E-I	118902	

**PASS-FIT-Adjusting ring incl. key for reinforced version punches**

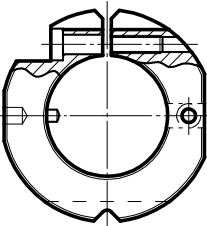
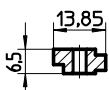
		size	machine group	part.-no.	price
	Adjusting ring incl. key	I/II	A-I	118VP1	
	Adjusting key		A-I	118903	

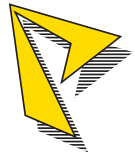

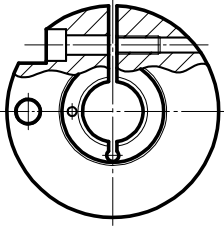
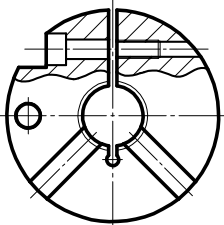
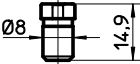
PASS-FIT-Adjusting ring incl. bolt for manual tool change					
		size	machine group	part.-no.	price
	Adjusting ring incl. bolt	I	A-D	1181P2	
	Adjusting ring incl. bolt	II	A-D	1182P2	
	Adjusting ring incl. bolt	III	A-D	1183P2	
	Adjusting ring incl. bolt outside Ø 95				
	Adjusting bolt		A-D	118901	

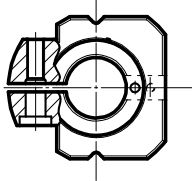
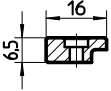
PASS-FIT-Adjusting ring incl. key for automatic tool changers					
		size	machine group	part.-no.	price
	Adjusting ring incl. key	I	S	1182PM	
	Adjusting ring incl. key	II	S	1181PM	
	Adjusting key		S	118904	



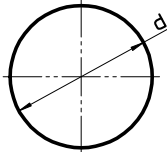
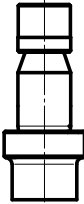
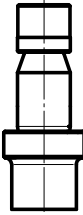
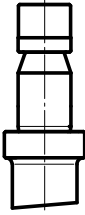

Am Steinkreuz 2  
D 95473 Creußen  
Phone: + 49 92 70 / 9 85 - 0  
Fax: + 49 92 70 / 9 85 - 99  
E-Mail: info@pass-ag.com  
Internet: www.pass-ag.com

Punches							
		HSS / Flat / 34,3 mm long		HSS / Flat / 37,8 mm long***		HSS / Whisper / 37,3 mm long	
							
size	dim. "d" in mm	part.-no.	price	part.-no.	price	part.-no.	price
<b>0/A</b>	1,00-6,00	107A01	*	107A11			
<b>0/B</b> (Schaft 10,5)	1,00-6,00	107C01	*	107C11			
<b>0/B</b>	6,01-10,50	107B01	*	107B11			
<b>I</b>	1,00-30,50	101111	*	103111		102111	*
<b>I/II</b>	30,51-38,00	1012M1	**			1022M1	**
<b>II</b>	30,51-40,00	101211		103211		102211	
	40,01-50,80	101221		103221		102221	
	50,81-60,00	101231		103231		102231	
	60,01-72,60	101241		103241		102241	
	72,61-80,20	101251		103251		102251	
<b>III</b>	76,21-105,00	101311				102311	
<b>reinforced Version</b>	-30,50	108111		108311		108211	
	-50	108121		108321		108221	
	-76,20	1081-1		1083-1		1082-1	

**PASS-FIT-System is not necessary  
for Round Tools,  
please use page 2 in Standard-Register**

\* also for machine group „S“  
\*\* only for machine group „S“  
\*\*\* only for machine group „I“

# Catalog 12/05-T

PASS-FIT-Punches  
SQUARE  
location 0°

System

## TRUMPF

# PASS STANZTECHNIK AG



Am Steinkreuz 2  
D 95473 Creußen  
Phone: + 49 92 70 / 9 85 - 0  
Fax: + 49 92 70 / 9 85 - 99  
E-Mail: info@pass-ag.com  
Internet: www.pass-ag.com

### PASS-FIT-Punch

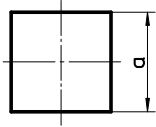
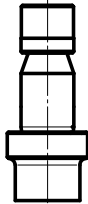
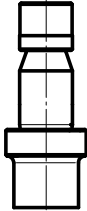
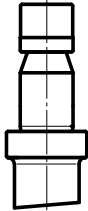
		HSS / Flat/ 34,3 mm long		HSS / Flat/ 37,8 mm long***		HSS / Whisper/ 37,3 mm long	
 location 0°							
Size	dim. "d" in mm	part.-no.	price	part.-no.	price	part.-no.	price
I	1,00-21,55	101112P1	*	103112P1		102112P1	*
I/II	21,56-26,85	1012M2P2	**			1022M2P2	**
II	21,56-28,25	101212P2		103212P2		102212P2	
	28,26-35,90	101222P2		103222P2		102222P2	
	35,91-42,40	101232P2		103232P2		102232P2	
	42,41-50,90	101242P2		103242P2		102242P2	
	50,91-53,90	101252P2		103252P2		102252P2	
III	53,91-74,25	101312P2				102312P2	
reinforced version	-21,55	108112P2		108312P2		108212P2	
	-28,25	108122P2		108322P2		108222P2	
	-53,90	1081-2P2		1083-2P2		1082-2P2	

Corner radius for square tools available on request. Surcharge: Punch +10%, Die +0%, Stripper +0%

\* Also for machine group „S“

\*\* Only for machine group „S“

\*\*\* Only for machine group „I“

# Catalog 12/05-T

PASS-FIT-Punches  
RECTANGLE  
location 0°

System

## TRUMPF

# PASS STANZTECHNIK AG



Am Steinkreuz 2  
D 95473 Creußen  
Phone: + 49 92 70 / 9 85 - 0  
Fax: + 49 92 70 / 9 85 - 99  
E-Mail: info@pass-ag.com  
Internet: www.pass-ag.com

PASS-FIT-Punch							
 location 0°		HSS / Flat / 34,3 mm long		HSS / Flat / 37,8 mm long***		HSS / Whisper / 37,3 mm long	
Size	dim. "d" in mm	part.-no.	price	part.-no.	price	part.-no.	price
I	1,00-30,50	101113P1	*	103113P1		102113P1	*
I/II	30,51-38,00	1012M3P2	**			1022M3P2	**
II	30,51-40,00	101213P2		103213P2		102213P2	
	40,01-50,80	101223P2		103223P2		102223P2	
	50,81-60,00	101233P2		103233P2		102233P2	
	60,01-72,00	101243P2		103243P2		102243P2	
	72,01-76,20	101253P2		103253P2		102253P2	
III	76,21-105,00	101313P2				102313P2	
reinforced version	-30,50	108113P2		108313P2		108213P2	
	-40,00	108123P2		108323P2		108223P2	
	-76,20	1081-3P2		1083-3P2		1082-3P2	

Corner radius for rectangle tools available on request. Surcharge: Punch +10%, Die +0%, Stripper +0%

\* Also for machine group „S“

\*\* Only for machine group „S“

\*\*\* Only for machine group „I“

# Catalog 12/05-T

**PASS-FIT-Punches**  
**OBLONG**  
location 0°

System

## TRUMPF

# PASS STANZTECHNIK AG

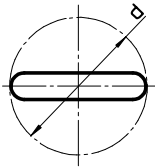
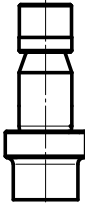
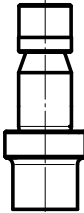
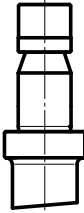

Am Steinkreuz 2  
D 95473 Creußen  
Phone: + 49 92 70 / 9 85 - 0  
Fax: + 49 92 70 / 9 85 - 99  
E-Mail: info@pass-ag.com  
Internet: www.pass-ag.com

PASS-FIT-Punch							
 location 0°		HSS / Flat / 34,3 mm long		HSS / Flat / 37,8 mm long***		HSS / Whisper / 37,3 mm long	
							
Size	dim. "d" in mm	part.-no.	price	part.-no.	price	part.-no.	price
I	1,00-30,50	101114P1	*	103114P1		102114P1	*
I/II	30,51-38,00	1012M4P2	**			1022M4P2	**
II	30,51-40,00	101214P2		103214P2		102214P2	
	40,01-50,80	101224P2		103224P2		102224P2	
	50,81-60,00	101234P2		103234P2		102234P2	
	60,01-72,00	101244P2		103244P2		102244P2	
	72,01-76,20	101254P2		103254P2		102254P2	
III	76,21-105,00	101314P2				102314P2	
reinforced version	-30,50	108114P2		108314P2		108214P2	
	-40,00	108124P2		108324P2		108224P2	
	-76,20	1081-4P2		1083-4P2		1082-4P2	

\* Also for machine group „S“

\*\* Only for machine group „S“

\*\*\* Only for machine group „I“

# Catalog 12/05-T

PASS-FIT-Shape-Punches  
**GROUP 1**  
 (SF01, SF02, SF04, SF05)  
 location 0°





System

# TRUMPF

## PASS STANZTECHNIK AG

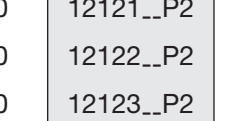
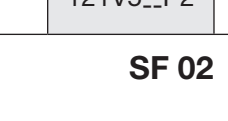

Am Steinkreuz 2  
 D 95473 Creußen  
 Phone: + 49 92 70 / 9 85 - 0  
 Fax: + 49 92 70 / 9 85 - 99  
 E-Mail: info@pass-ag.com  
 Internet: www.pass-ag.com

PASS-FIT-Punch							
		HSS / Flat / 34,3 mm long		HSS / Flat / 37,8 mm long***		HSS / Whisper / 37,3 mm long	
SF 01  SF 02  SF 04  SF 05  to complete part.-no. location 0°							
Size	dim. "d" in mm	part.-no.	price	part.-no.	price	part.-no.	price
I	1,00-30,50	12111__P1	*	12311__P1		12211__P1	*
I/II	30,51-38,00	121M1__P2	**			122M1__P2	**
II	30,51-40,00	12121__P2		12321__P2		12221__P2	
	40,01-50,80	12122__P2		12322__P2		12222__P2	
	50,81-60,00	12123__P2		12323__P2		12223__P2	
	60,01-72,00	12124__P2		12324__P2		12224__P2	
	72,01-76,20	12125__P2		12325__P2		12225__P2	
III	76,21-105,00	12131__P2				12231__P2	
reinforced version	-30,50	V2111__P2		V2311__P2		V2211__P2	
	-40,00	121V1__P2		123V1__P2		122V1__P2	
	-76,20	121V5__P2		123V5__P2		122V5__P2	

SF 01

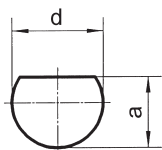

SF 02

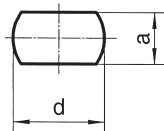

SF 04

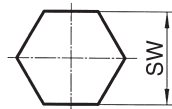

SF 05

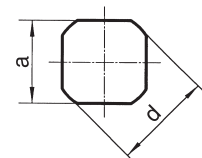

\* Also for machine group „S“  
 \*\* Only for machine group „S“  
 \*\*\* Only for machine group „I“

# Catalog 12/05-T

PASS-FIT-Shape-Punches  
GROUP 2

(SF03, SF07, SF13, SF17)

location 0°-90°-180°-270°

System

# TRUMPF

## PASS STANZTECHNIK AG



Am Steinkreuz 2

D 95473 Creußen

Phone: + 49 92 70 / 9 85 - 0

Fax: + 49 92 70 / 9 85 - 99

E-Mail: info@pass-ag.com

Internet: www.pass-ag.com

### PASS-FIT-Punch

		HSS / Flat / 34,3 mm long		HSS / Flat / 37,8 mm long***		HSS / Whisper / 37,3 mm long	
SF 03							
SF 07							
SF 13							
SF 17							
to complete part.-no.							
location 0°-90°-180°-270°							
Size	dim. "d" in mm	part.-no.	price	part.-no.	price	part.-no.	price
I	1,00-30,50	12111__P1	*	12311__P1		12211__P1	*
I/II	30,51-38,00	121M1__P2	**			122M1__P2	**
II	30,51-40,00	12121__P2		12321__P2		12221__P2	
	40,01-50,80	12122__P2		12322__P2		12222__P2	
	50,81-60,00	12123__P2		12323__P2		12223__P2	
	60,01-72,00	12124__P2		12324__P2		12224__P2	
	72,01-76,20	12125__P2		12325__P2		12225__P2	
III	76,21-105,00	12131__P2				12231__P2	
reinforced version	-30,50	V2111__P2		V2311__P2		V2211__P2	
	-40,00	121V1__P2		123V1__P2		122V1__P2	
	-76,20	121V5__P2		123V5__P2		122V5__P2	

SF 03

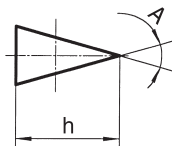

SF 07

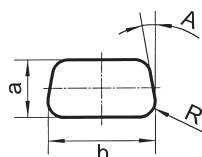

SF 13

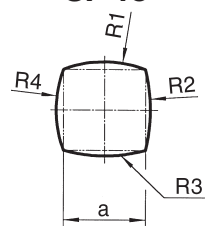

SF 17

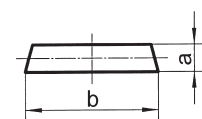

\* Also for machine group „S“

\*\* Only for machine group „S“

\*\*\* Only for machine group „I“

# Catalog 12/05-T

PASS-FIT-Shape-Punches  
GROUP 3

(SF06, SF08, SF14, SF16)  
location 0°-90°-180°-270°





System

# TRUMPF

## PASS STANZTECHNIK AG

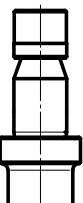
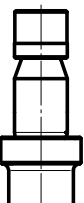
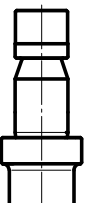

Am Steinkreuz 2  
D 95473 Creußen  
Phone: + 49 92 70 / 9 85 - 0  
Fax: + 49 92 70 / 9 85 - 99  
E-Mail: info@pass-ag.com  
Internet: www.pass-ag.com

PASS-FIT-Punch							
		HSS / Flat / 34,3 mm long		HSS / Flat / 37,8 mm long***		HSS / Whisper / 37,3 mm long	
SF 06  SF 08  SF 14  SF 16  to complete part.-no. location 0°-90°-180°-270°							
Size	dim. "d" in mm	part.-no.	price	part.-no.	price	part.-no.	price
I	1,00-30,50	12111__P1	*	12311__P1		12211__P1	*
I/II	30,51-38,00	121M1__P2	**			122M1__P2	**
II	30,51-40,00	12121__P2		12321__P2		12221__P2	
	40,01-50,80	12122__P2		12322__P2		12222__P2	
	50,81-60,00	12123__P2		12323__P2		12223__P2	
	60,01-72,00	12124__P2		12324__P2		12224__P2	
	72,01-76,20	12125__P2		12325__P2		12225__P2	
III	76,21-105,00	12131__P2				12231__P2	
reinforced version	-30,50	V2111__P2		V2311__P2		V2211__P2	
	-40,00	121V1__P2		123V1__P2		122V1__P2	
	-76,20	121V5__P2		123V5__P2		122V5__P2	

SF 06

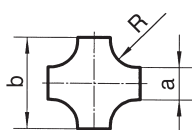

SF 08

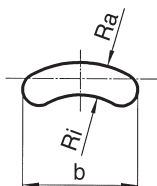

SF 14

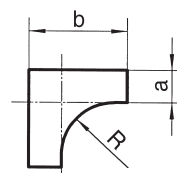

SF 16

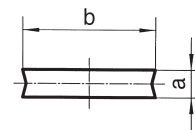

\* Also for machine group „S“  
 \*\* Only for machine group „S“  
 \*\*\* Only for machine group „I“

# Catalog 12/05-T

PASS-FIT-Shape-Punches  
GROUP 4

(SF09, SF10, SF11, SF12, SF15)

location 0°-90°-180°-270°

System

# TRUMPF

## PASS STANZTECHNIK AG



Am Steinkreuz 2

D 95473 Creußen

Phone: + 49 92 70 / 9 85 - 0

Fax: + 49 92 70 / 9 85 - 99

E-Mail: info@pass-ag.com

Internet: www.pass-ag.com

### PASS-FIT-Punch

		HSS / Flat/ 34,3 mm long	HSS / Flat/ 37,8 mm long***	HSS / Whisper/ 37,3 mm long			
SF 09							
SF 10							
SF 11							
SF 12							
SF 15							
to complete part.-no. location 0°-90°-180°-270°							
Size	dim. "d" in mm	part.-no.	price	part.-no.	price	part.-no.	price
I	1,00-30,50	12111__P1	*	12311__P1		12211__P1	*
I/ II	30,51-38,00	121M1__P2	**			122M1__P2	**
II	30,51-40,00	12121__P2		12321__P2		12221__P2	
	40,01-50,80	12122__P2		12322__P2		12222__P2	
	50,81-60,00	12123__P2		12323__P2		12223__P2	
	60,01-72,00	12124__P2		12324__P2		12224__P2	
	72,01-76,20	12125__P2		12325__P2		12225__P2	
III	76,21-105,00	12131__P2				12231__P2	
reinforced version	-30,50	V2111__P2		V2311__P2		V2211__P2	
	-40,00	121V1__P2		123V1__P2		122V1__P2	
	-76,20	121V5__P2		123V5__P2		122V5__P2	

SF 09

SF 10

SF 11

SF 12

SF 15

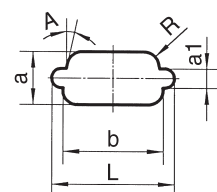
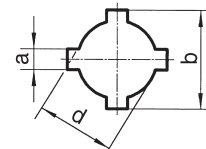
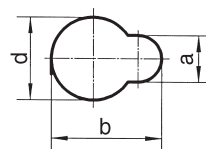
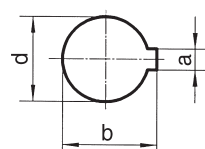
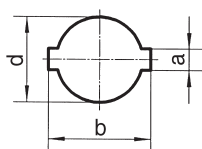

\* Also for machine group „S“

\*\* Only for machine group „S“

\*\*\* Only for machine group „I“





Standard Center-Punch-Tool  
Solid version / Adjustable version

Special-Center-Punch-Tool  
downform / upform

Marking tool / Letter-marking-Multitool 10-station

# Catalog 12/05-T

Center-Punch-Tool  
downform  
- solid version

System

## TRUMPF

### PASS STANZTECHNIK AG



Am Steinkreuz 2  
D 95473 Creußen  
Phone: + 49 92 70 / 9 85 - 0  
Fax: + 49 92 70 / 9 85 - 99  
E-Mail: info@pass-ag.com  
Internet: www.pass-ag.com

Center-Punch-Tool "solid version"			
description	sheet thickness range, mm	part.-no.	price
complete tool consisting of: -punch chuck -center-punch -die	s = 1,00-4,50	1S092A	*
	s = 4,51-8,00	1S092B	*
	s = 8,01-11,50	1S092C	*
	s = 9,01-12,50	1S092D	*

Spare-center-punch				
description	sheet thickness range, mm	part.-no.	price	length "L"
center-punch	s = 1,00-4,50	1S0921	*	55,3 mm
center-punch	s = 4,51-8,00	1S0922	*	51,3 mm
center-punch	s = 8,01-11,50	1S0923	*	47,3 mm
center-punch	s = 9,01-12,50	1S0924	*	46,3 mm

Spare screw		
description	part.-no.	price
set screw M14 x 1,5 x 12	1S0925	*

\* also for machine group "S"

Suitable adjusting ring: **118102**, **118101** or **11820M** (see under „accessories“ page 2/3)

# Catalog 12/05-T

Center-Punch-Tool  
downform  
- adjustable version

System

## TRUMPF

### PASS STANZTECHNIK AG



Am Steinkreuz 2  
D 95473 Creußen  
Phone: + 49 92 70 / 9 85 - 0  
Fax: + 49 92 70 / 9 85 - 99  
E-Mail: info@pass-ag.com  
Internet: www.pass-ag.com

Center-Punch-Tool "infinitely adjustable"			
description	sheet thickness range, mm	part.-no.	price
<b>complete tool</b>  <b>consisting of:</b> -adapter -adjusting screw -center-punch -spring -die	s = 1,00-6,00	1S090A	
	s = 6,01-12,00	1S090B	

Spare-center-punch				
description	sheet thickness range, mm	part.-no.	price	length "L"
center-punch	s = 1,00-6,00	1S0904		49 mm
center-punch	s = 6,01-12,00	1S0905		43 mm

Spare screw			
description	sheet thickness range, mm	part.-no.	price
thread screw with shoulder	s = 1,00-12,00	1S0902	

Spare spring			
description	sheet thickness range, mm	part.-no.	price
compression spring	s = 1,00-12,00	1S0903	

\* Suitable adjusting ring: **118V01** (see under „accessories“ page 2)

# Catalog 12/05-T

Center-Punch-Tool  
downform

- automatic sheet thickness  
adjustment

System

# TRUMPF

## PASS STANZTECHNIK AG

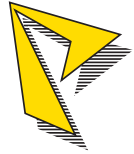

Am Steinkreuz 2  
D 95473 Creußen  
Phone: + 49 92 70 / 9 85 - 0  
Fax: + 49 92 70 / 9 85 - 99  
E-Mail: info@pass-ag.com  
Internet: www.pass-ag.com

### Downformed-Center-Punch-Tool with automatic sheet thickness and depth adjustment for $s = 1 - 3\text{mm}$

description	part.-no.	price
complete tool from 1S2601 - 1S2609	1S2600	

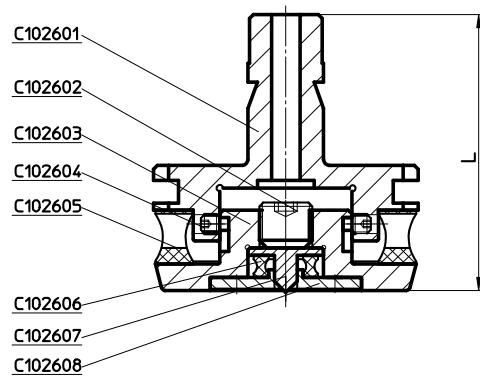

### Spare parts

description	part.-no.	price
adjusting screw	1S2602	
retaining screws (4 pieces)	1S2604	
spring (polyurethane)	1S2605	
tension element	1S2606	
center-punch	1S2607	
center-punch-guide	1S2608	
die	1S2609	

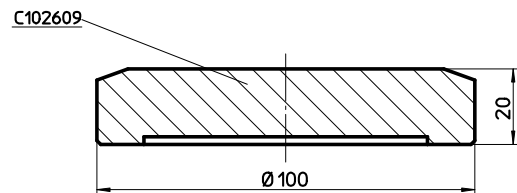
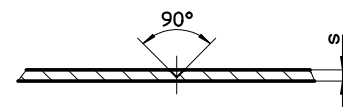

# Catalog 12/05-T

Center-Punch-Tool  
upform  
- adjustable depth

System

# TRUMPF

## PASS STANZTECHNIK AG



Am Steinkreuz 2  
D 95473 Creußen  
Phone: + 49 92 70 / 9 85 - 0  
Fax: + 49 92 70 / 9 85 - 99  
E-Mail: info@pass-ag.com  
Internet: www.pass-ag.com



### Upform-Center-Punch-Tool with adjustable center depth

description	part.-no.	price
complete tool from 1S2801 - 1S2808	1S2800	

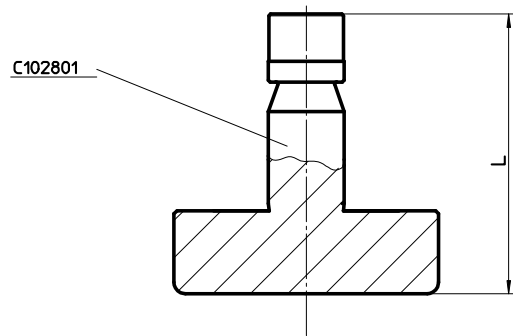

### Spare parts

description	part.-no.	price
upper part	1S2801	
stripper	1S2804	
center-punch	1S2805	
spring (polyurethane)	1S2806	
adjusting screw	1S2809	

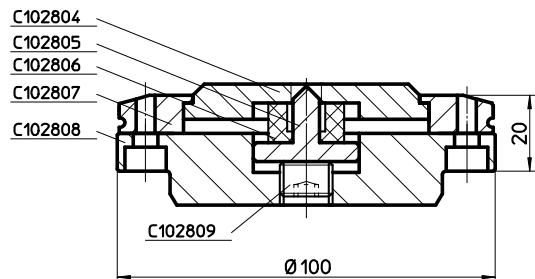
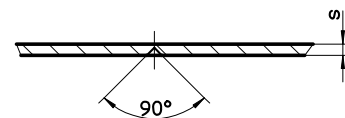



Am Steinkreuz 2  
 D 95473 Creußen  
 Phone: + 49 92 70 / 9 85 - 0  
 Fax: + 49 92 70 / 9 85 - 99  
 E-Mail: info@pass-ag.com  
 Internet: www.pass-ag.com

Marking tool complete				
description	sheet thickness range, mm	part.-no.	price	
<b>complete tool</b>  consisting of: -adapter -adjusting ring -sign insert -spring -stripper Ø 20 -die flat	s = 0,80-8,00	1S390W		

Marking punch complete				
description	sheet thickness range, mm	part.-no.	price	
<b>marking punch complete</b> (incl. adjusting ring)	s = 0,80-8,00	1S3900		

Spare marking insert				
description	sheet thickness range, mm	part.-no.	price	
<b>spare etching insert</b>	s = 0,80-8,00	1S3930		

Spare die				
description	sheet thickness range, mm	part.-no.	price	
<b>spare die (flat)</b>	s = 0,80-8,00	1S3940		

# Catalog 12/05-T

Letter-Marking-Multitool  
10-station  
for Machine Group I

System

# TRUMPF

## PASS STANZTECHNIK AG



Am Steinkreuz 2  
D 95473 Creußen  
Phone: + 49 92 70 / 9 85 - 0  
Fax: + 49 92 70 / 9 85 - 99  
E-Mail: info@pass-ag.com  
Internet: www.pass-ag.com

Letter marking punch for 10-station-Multitool			
Type	letter height	part.-no.	price
10-station	4 mm	113P10-?	

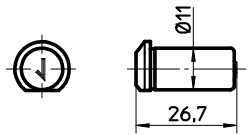

**instead of "?" please add letter, number or special sign to the part.-no.**

standard letters :	-A	-K	-U	-1	-/ (slash)
	-B	-L	-V	-2	-- (minus)
	-C	-M	-W	-3	-. (dot)
	-D	-N	-X	-4	
	-E	-O	-Y	-5	
	-F	-P	-Z	-6	
	-G	-Q		-7	
	-H	-R		-8	
	-I	-S		-9	
	-J	-T		-0	

Stripper for 10-station-Multitool			
Type	shape	part.-no.	price
10-station	10 x Ø 12,00 mm	113PA10	



Die for 10-station-Multitool			
Type	shape	part.-no.	price
10-station	without holes (size II)	113PM10	

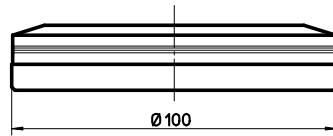





PU-Stripper / Push-out Stripper

Coating / Polished tools

Rotary Die Adapter / Nibbling Oil

Nibbling Tools



PU-stripper								
profile	type of spring	dim. "d" in mm	for "flat" punches			for "whisper" punches		
			H in mm	part.-no.	price	H in mm	part.-no.	price
blank	1	-12,00	19	1S013810		22	1S013820	
	2	-30,50	25	1S013830		28	1S013840	
	3	-48,00	25	1S013850		28	1S013860	
round	1	-12,00	19	1S013811		22	1S013821	
	2	-30,50	25	1S013831		28	1S013841	
	3	-48,00	25	1S013851		28	1S013861	
other shapes	1	-12,00	19	1S013812		22	1S013822	
	2	-30,50	25	1S013832		28	1S013842	
	3	-48,00	25	1S013852		28	1S013862	

**spring type 1\***

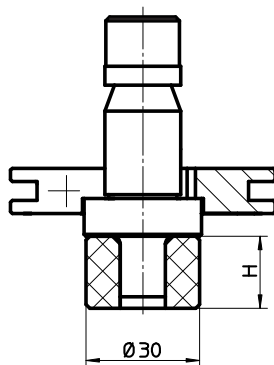

**spring type 2**

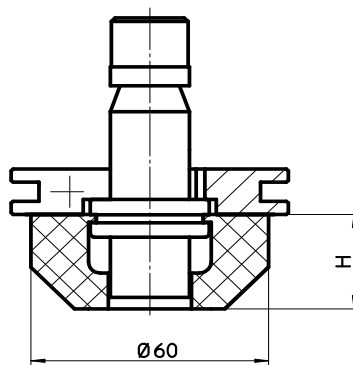

**spring type 3**

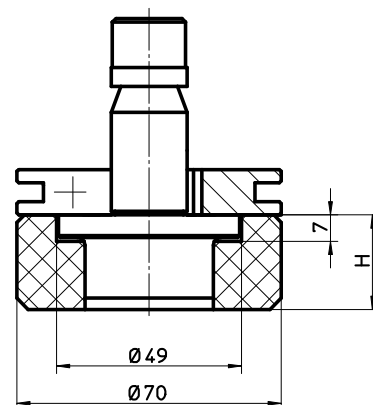

**used for:**

- noise reduction
- punching close to forming

**Caution:** Severe wearing of the polyurethane springs may result when they are in contact with punched holes or sheet edges.

\* also for machine group „S“



Am Steinkreuz 2  
 D 95473 Creußen  
 Phone: + 49 92 70 / 9 85 - 0  
 Fax: + 49 92 70 / 9 85 - 99  
 E-Mail: info@pass-ag.com  
 Internet: www.pass-ag.com

### Push-out stripper for machine group "F/H/I"

shape	part.-no.	price	
round	1S21001		
square	1S21002		
rectangle	1S21003		
oblong	1S21004		
special shapes	1S21000		
spare screws (4 pieces per set)	1S21091		
spare springs (4 pieces per set)	1S21092		

### Push-out stripper for machine group "S"

shape	part.-no.	price	
round	1S21101		
square	1S21102		
rectangle	1S21103		
oblong	1S21104		
special shapes	1S21100		
spare screws (4 pieces per set)	1S21191		
spare springs (4 pieces per set)	1S21192		



Am Steinkreuz 2  
 D 95473 Creußen  
 Phone: + 49 92 70 / 9 85 - 0  
 Fax: + 49 92 70 / 9 85 - 99  
 E-Mail: info@pass-ag.com  
 Internet: www.pass-ag.com

### TICN-(Titanium-Carbo-Nitride) Coating for longer tool life

size	dim. "d" in mm	surcharge
0	- 10,50	
I	- 30,50	
II	- 76,20	
III	- 105,00	
Multitool	- 16,00	
slitting blade	- 60,00	
slitting blade	- 80,00	

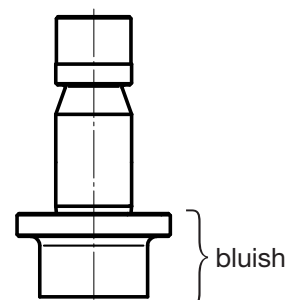

### T-MAX-Coating (double-coating) for longer tool life and better sliding effect

size	dim. "d" in mm	surcharge
0	- 10,50	
I	- 30,50	
II	- 76,20	
III	- 105,00	
Multitool	- 16,00	
slitting blade	- 60,00	
slitting blade	- 80,00	

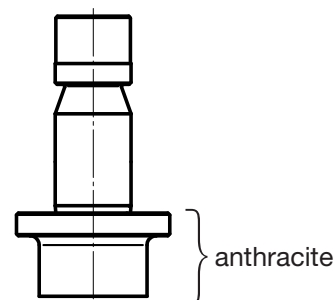

# Catalog 12/05-T

Polished tools  
(for scratch-less parts)

System

# TRUMPF

## PASS STANZTECHNIK AG



Am Steinkreuz 2  
D 95473 Creußen  
Phone: + 49 92 70 / 9 85 - 0  
Fax: + 49 92 70 / 9 85 - 99  
E-Mail: info@pass-ag.com  
Internet: www.pass-ag.com

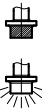

### Surcharge for polished tools

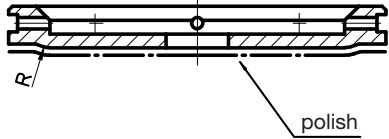
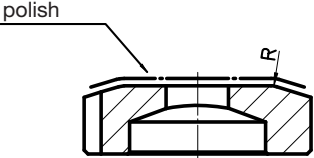
description	surcharge	
stripper for machine group "S"		
stripper size II		
stripper size III		
adapter ring for stripper size II/III		
die size I		
die size II		
die size III		
adapter ring for die size II - I		
adapter ring for die size III - II		
adapter ring for die size III - I		



Am Steinkreuz 2  
D 95473 Creußen  
Phone: + 49 92 70 / 9 85 - 0  
Fax: + 49 92 70 / 9 85 - 99  
E-Mail: info@pass-ag.com  
Internet: www.pass-ag.com

**Rotary die adapter from size II to size I**

size	part.-no.	price	
reduced from size II to I	1S1900		

**Rotary die adapter from size III to size II**

size	part.-no.	price	
reduced from size III to II	1S1950		

Catalog 12/05-T  
Nibbling Oil

System

**TRUMPF**

**PASS STANZTECHNIK AG**



Am Steinkreuz 2  
D 95473 Creußen  
Phone: + 49 92 70 / 9 85 - 0  
Fax: + 49 92 70 / 9 85 - 99  
E-Mail: [info@pass-ag.com](mailto:info@pass-ag.com)  
Internet: [www.pass-ag.com](http://www.pass-ag.com)



**Nibbling Oil :**

**We are able to supply you with a special nibbling oil.**

**This oil is especially for mild- and stainless-steel**



# Catalog 12/05-T

Nibbling tools  
for hand-guided  
machines

System







## TRUMPF

### PASS STANZTECHNIK AG

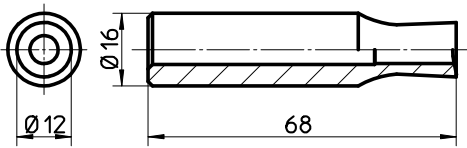

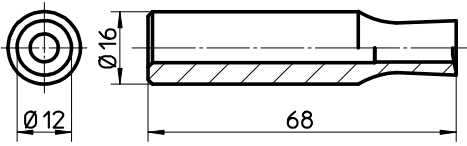

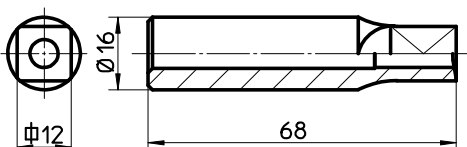
Am Steinkreuz 2  
D 95473 Creußen  
Phone: + 49 92 70 / 9 85 - 0  
Fax: + 49 92 70 / 9 85 - 99  
E-Mail: info@pass-ag.com  
Internet: www.pass-ag.com

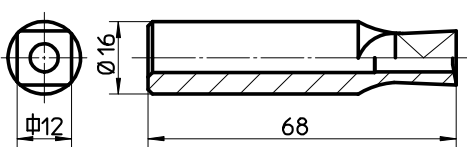
#### Nibbling punch with shaft diameter 16mm



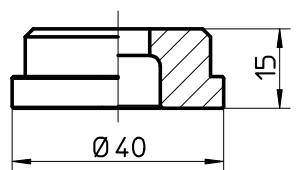

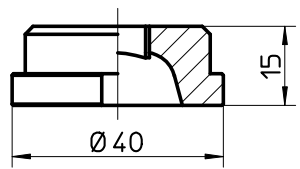

shape	description	part.-no.	price	
round 	nibbling punches for mild-steel  round 12	1S0722		
round 	nibbling punches for stainless-steel  round 12	1S0727		
square 	nibbling punches for mild-steel  square 12	1S0721		
square 	nibbling punches for stainless-steel  square 12	1S0726		

#### Nibbling die with outside diameter 40mm

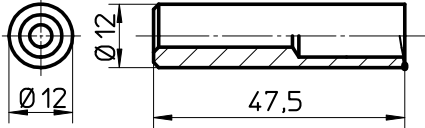

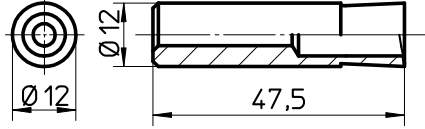
shape	description	part.-no.	price	
round 	nibbling die round 12 + clearance	1S0724		
square 	nibbling die square 12 + clearance	1S0723		

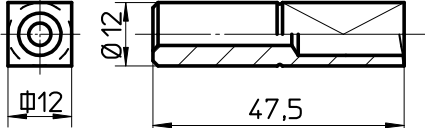

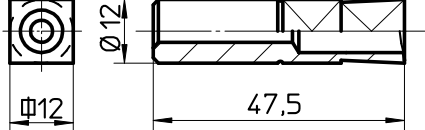
#### Nibbling punch with shaft diameter 12mm

shape	description	part.-no.	price	
round 	nibbling punches for mild-steel  round 12	1S0702		
round 	nibbling punches for stainless-steel  round 12	1S0710		
square 	nibbling punches for mild-steel  square 12	1S0701		
square 	nibbling punches for stainless-steel  square 12	1S0711		

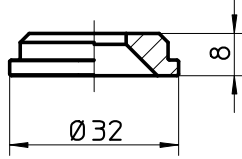
#### Nibbling die with outside diameter 32mm

shape	description	part.-no.	price	
round 	nibbling die round 12 + clearance	1S0704		
square 	nibbling die square 12 + clearance	1S0703		